

HOLEMAKER PRO 35 MS

PIPE DRILLING MACHINE



Cutters
35mm



Twist Drills
16mm

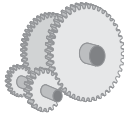

Speed
350 rpm

Features

- All of the features of the standard Pro 35 machine, with the addition of 4x Permanent rare earth magnets allow for external drilling of pipe minimum diameter 300mm or internal drilling of pipe minimum diameter 1000mm
- Quality, Compact & Robust European Made Machine
- Ideal for on-site and overhead tasks
- Solid, robust construction
- Dual rail slide system provides rigidity and eliminates the need for gib adjustments
- Gravity feed, through spindle coolant system
- Magnetically attached coolant bottle, which can be easily removed and attached to the work piece, allowing coolant feed whilst drilling in horizontal applications
- The feed handles can be placed on either the left or right hand side
- Cutter guard system is easy to use and practical.
- Smart magnet technology to ensure sufficient magnetic adhesion
- Comes complete in metal carry case



PART NO. HMPRO35-MS

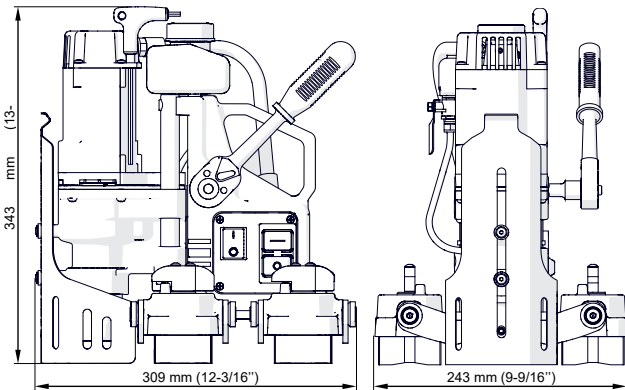

Part No.	Capacity (Diameter)	Capacity (Depth)	Capacity (Weldon Shank Twist Drills)	Motor Power	Input Power	Speed	Weight	Magnetic Dead Lift	Stroke	Height (min / max)
HMPRO35MS	35mm	35mm	16mm	920 Watt	1000 Watt Single Phase 240V	350rpm	14.0kg	6000Nm On 25mm Steel Plate	70mm	343 / 413mm