

HOLEMAKER PRO 35 T3

THIN WORKPIECE MACHINE



Cutters
35mm



Twist Drills
16mm

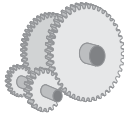

Speed
350 rpm

Features

- All of the features of the standard Pro 35 machine, with the addition of a new highly advance T3 magnet, allowing minimum material thickness of 3mm
- Quality, Compact & Robust European Made Machine
- Ideal for on-site and overhead tasks
- Solid, robust construction
- Dual rail slide system provides rigidity and eliminates the need for gib adjustments
- Gravity feed, through spindle coolant system
- Magnetically attached coolant bottle, which can be easily removed and attached to the work piece, allowing coolant feed whilst drilling in horizontal applications
- The feed handles can be placed on either the left or right hand side
- Cutter guard system is easy to use and practical.
- Smart magnet technology to ensure sufficient magnetic adhesion
- Comes complete in metal carry case

PART NO. HMPRO35-T3

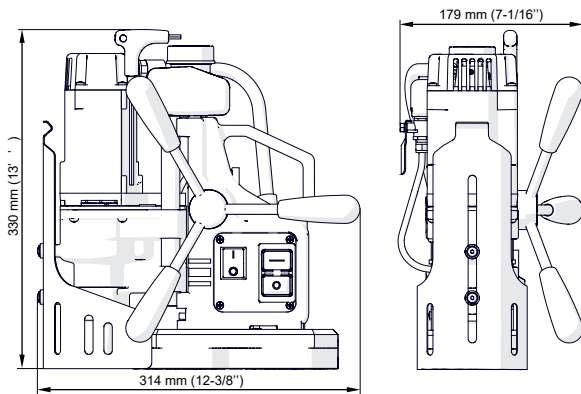

Part No.	Capacity (Diameter)	Capacity (Depth)	Capacity (Weldon Shank Twist Drills)	Motor Power	Input Power	Speed	Weight	Magnetic Dead Lift	Stroke	Height (min / max)
HMPRO35T3	35mm	52mm	16mm	920 Watt	1000 Watt Single Phase 240V	350rpm	11.0kg	9000Nm On 25mm Steel Plate	70mm	330 / 400mm