

HOLEMAKER HMPRO75SR

Holemaker Portable Magnetic Drilling Machine

OPERATOR'S MANUAL

⚠ WARNING!

BEFORE USE, ENSURE EVERYONE USING THIS MACHINE READS AND UNDERSTANDS ALL SAFETY AND OPERATING INSTRUCTIONS IN THIS MANUAL .



EYE PROTECTION
REQUIRED



HEARING PROTECTION
REQUIRED



NEVER PLACE
FINGERS NEAR
CUTTING AREA OR
MACHINE ARBOR



LINE VOLTAGE
PRESENT



BEWARE OF
ROTATING
MACHINE PARTS



Serial # _____

Date of Purchase _____

LIMITED WARRANTY

Industrial Tool & Machinery Sales (hereinafter referred to as ITMS) will, within twelve (12) months from the original date of purchase, repair or replace any goods found to be defective in materials or workmanship.

This warranty is void if the item has been damaged by accident, neglect, improper service or other causes not arising out of defects in materials or workmanship. This warranty does not apply to machines and/or components which have been altered, changed, or modified in any way, or subjected to overloading or use beyond recommended capacities and specifications. Worn componentry due to normal wear and tear is not a warranty claim. Goods returned defective shall be returned prepaid freight to ITMS or agreed repair agent, which shall be the buyer's sole and exclusive remedy for defective goods. ITMS accepts no additional liability pursuant to this guarantee for the costs of travelling or transportation of the product or parts to and from ITMS or the service agent or dealer, such costs are not included in this warranty.

Our goods come with guarantees which cannot be excluded under the Australian Consumer Law. You are entitled to replacement or refund for a major failure and to compensation for other reasonably foreseeable loss or damage. You are also entitled to have the goods repaired or replaced if the goods fail to be of acceptable quality and the failure does not amount to a major failure.

THE MANUFACTURER RESERVES THE RIGHT TO MAKE IMPROVEMENTS AND MODIFICATIONS TO DESIGN WITHOUT PRIOR NOTICE.

PRODUCTS IMPORTED AND DISTRIBUTED NATIONALLY BY:



INDUSTRIAL TOOL & MACHINERY SALES

18 BUSINESS ST, YATALA QLD 4207

T: 07 3287 1114 E: sales@industrialtool.com.au

F: 07 3287 1115 W: www.industrialtool.com.au

TABLE OF CONTENTS

Important Safety Instructions	3-4
Power Supply Requirement	5
Technical Data	6
Special Instructions	7
Contents of Package	7
Machine Operation	8-10
Maintenance and Service	11
Basic Troubleshooting	12

IMPORTANT SAFETY INSTRUCTIONS

WARNING!

WHEN USING ELECTRICAL TOOLS, BASIC SAFETY PRECAUTIONS SHOULD ALWAYS BE FOLLOWED TO REDUCE RISK OF FIRE, ELECTRIC SHOCK AND PERSONAL INJURY .

READ AND SAVE ALL INSTRUCTIONS FOR FUTURE REFERENCE.

1. Keep Work Area Clean
 - Cluttered areas and benches increase risk of injuries.
2. Consider Work Area Environment
 - Do not expose power tools to rain.
 - Do not use power tools in damp or wet locations.
 - Keep work area well lit.
 - Do not use tool in presence of flammable liquids or gases.
3. Guard Against Electric Shock
 - Prevent body contact with grounded surfaces. For example: pipes, radiators, ranges and refrigerator enclosures.
4. Keep Children Away
 - Do not let visitors contact tool or extension cord.
 - All visitors should be kept away from work area.
5. Store Idle Tools
 - When not in use, tools should be stored in a dry, high and locked-up place, out of reach of children.
6. Do Not Force Tool
 - It will do the job better and safer at the rate for which it was intended.
7. Use Right Tool
 - Do not force a small tool or attachment to do the job of a heavy-duty tool.
 - Do not use tool for unintended purpose. For example: Do not use a circular saw for cutting tree limbs or logs.
8. Dress Properly
 - Do not wear loose clothing or jewellery. They can be caught in moving parts.
 - Rubber gloves and non-skid footwear are recommended when working outdoors.
 - Wear protective hair covering to contain long hair.
 - Always wear safety glasses
 - Use face or dust mask if necessary
 - Use hearing protection
9. Do Not Abuse Electrical Cord
 - Never carry tool by cord or yank it to disconnect from receptacle.
 - Keep cord away from heat, oil and sharp edges.
10. Secure Work
 - Use clamps or a vise to hold work. It's safer than using your hand and it frees both hands to operate tool.
11. Do Not Overreach
 - Keep proper footing and balance at all times.

IMPORTANT SAFETY INSTRUCTIONS

12. Maintain Tools With Care
 - Keep tools sharp and clean for better and safer performance.
 - Follow instructions for lubricating and changing accessories.
 - Inspect tool cords periodically and if damaged, have repaired by authorized service facility.
 - Inspect extension cords periodically and replace if damaged.
 - Keep handles dry, clean, and free from oil and grease.
13. Disconnect Tools
 - Unplug when not in use, before servicing, and when changing accessories, such as cutters.
14. Remove Adjusting Keys And Wrenches
 - Form habit of checking to see that keys and adjusting wrenches are removed from tool before turning it on.
15. Avoid Unintentional Starting
 - Do not carry a plugged-in tool. Always disconnect from power source before moving.
 - Be sure switches are off before connecting to a power source.
16. Outdoor Use Of Extension Cords
 - When tool is used outdoors, use only extension cords intended for use outdoors and so marked.
17. Stay Alert
 - Watch what you are doing. Use common sense. Do not operate tool when you are tired.
 - Do not use when taking medications that may cause drowsiness.
18. Check Damaged Parts
 - Before further use of the tool, any damaged parts should be repaired and performance verified prior to operation.
 - Check alignment of moving parts, binding of parts, breakage of parts, mounting, and any other conditions that may affect its operation. Any part that is damaged should be properly repaired or replaced by an authorized service center.
 - Do not use this tool if switches do not turn it on and off. Have defective switches replaced by authorized service center.
19. Use Cutter Guard
 - Always use cutter guard supplied with machine to reduce the risk of injury. (refer fig. 1)

Fig. 1



POWER SUPPLY REQUIREMENTS

Prior to use check condition of the power cord, which has to be free of any cuts, or similar damages.

Attention!: This unit has a class one of insulation and absolutely requires the power source to be equipped with a protection circuit.

Power source should be protected with the difference-current circuit cut-out and protected with a 10A fuse - for 230V. At building sites, power should be supplied from a separation transformer such as Type AVM, with minimum power of 2000 VA and with second class protection.

GROUNDING INSTRUCTIONS

⚠ WARNING!

Improperly connecting the grounding wire can result in the risk of electrical shock. Check with a qualified electrician if you are in doubt as to whether the outlet is properly grounded. Do not modify the plug provided with tool. Never remove the grounding prong from the plug. If the cord or plug is damaged, have it repaired before using. If the plug will not fit the outlet, have a proper outlet installed by a qualified electrician. The Holemaker must be plugged into an appropriate outlet, properly installed and grounded in accordance with all codes and ordinances. The plug and outlet should look similar to those in Figure A. If in doubt of proper grounding, call a qualified electrician.

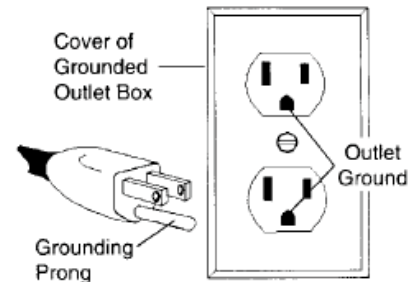

Fig. A

⚠ WARNING!

DO NOT USE HOLEMAKER DRILLING MACHINES ON SURFACES OR MATERIALS BEING WELDED. DOING SO CAN RESULT IN DAMAGE TO THE DRILLING MACHINE.

EXTENSION CORDS

Use only 3-wire extension cords that have 3-prong grounding-type plugs and 3-pole receptacles that accept the tool's plug. Replace or repair damaged cords. Make sure your extension cord is in good condition. When using an extension cord, be sure to use one heavy enough to carry the current your product will draw. An undersized cord will cause a drop in line voltage resulting in loss of power and overheating. See table for the correct size to use depending on cord length and nameplate amperage rating. If in doubt, use the next heavier gauge. The smaller the gauge number, the heavier the cord.

MINIMUM GAUGE FOR EXTENSION CORDS				
VOLTS	TOTAL LENGTH OF CORD IN METRES			
240V	0 - 15	15 - 30	30 - 60	60 - 90
AMPERAGE				
0-6	18	16	16	14
6-10	18	16	14	12
10-12	16	16	14	12
12-16	14	12	NOT RECOMMENDED	
	RECOMMENDED		WIRE GAUGE	

DRIP LOOP: To help prevent cutting fluids from traveling along power cord and contacting power source, tie a drip loop in power cord as shown in Figure C.

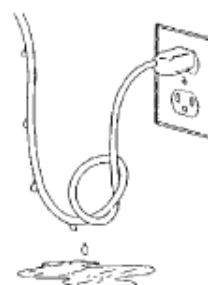
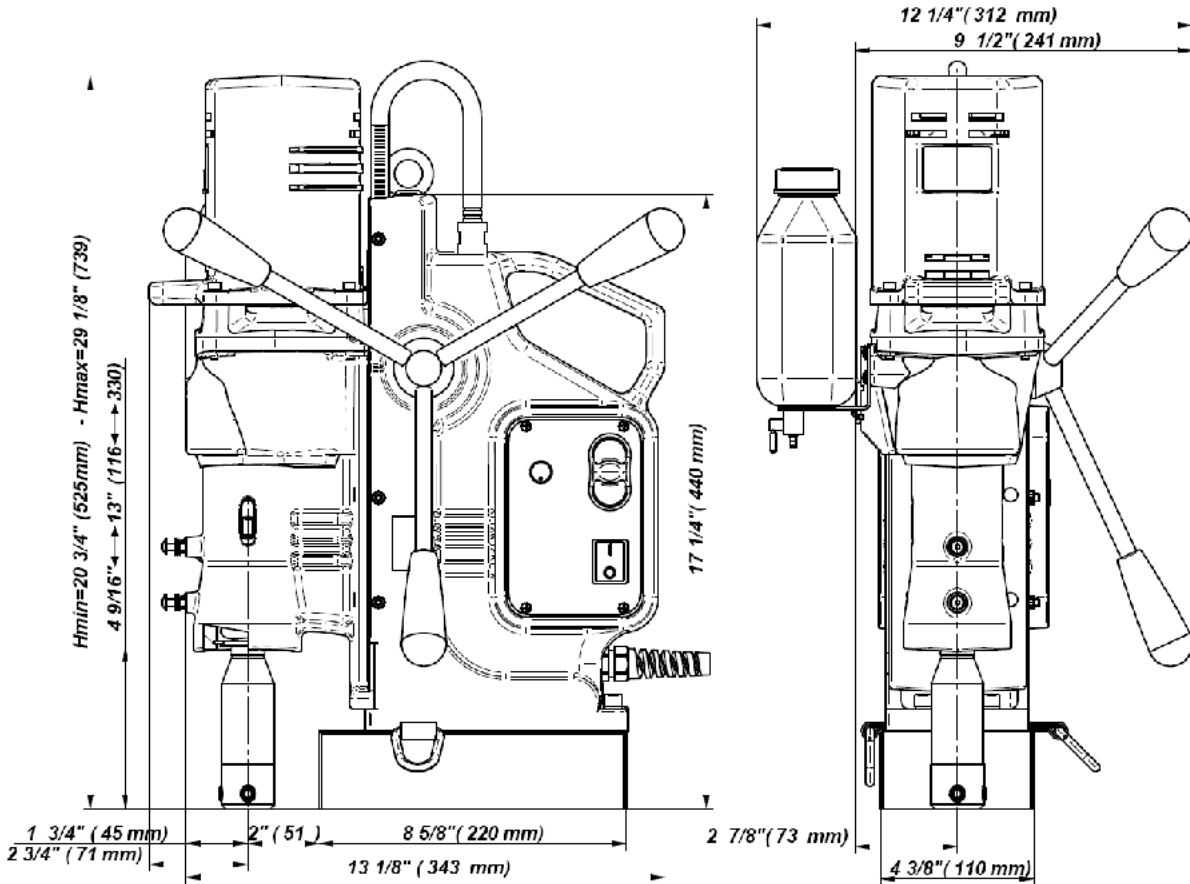

Fig. C

TECHNICAL DATA



- Supply voltage: 220-240V/ 50-60 Hz.
- Motor power 1650 W
- Total power 1800 W
- Machine speeds (under load): Gear 1: 80-160rpm
..... Gear 2: 210-420rpm
- Insulation class First
- Arbor bore MT 3
- Tool holder ($\frac{3}{4}"$ Weldon) 19.05 mm
- Capacities: max. Holemaker cutter diameter 75 mm
..... max. drilling depth with standard arbor 75mm
..... max. drilling depth with optional arbor 110mm
- Magnet Dead Lift (on 25 mm plate) 19500 N

Dimensions:

- electromagnetic base 110x220x56 mm
- Length of the power cord 3 m
- Total weight 27.0 kg
- Noise level 85 dB

SPECIAL INSTRUCTIONS

1. Read and follow operator's manual thoroughly.
2. DO NOT touch rotating cutter or parts.
3. Always stop machine completely and unplug from power source before changing cutters, clearing swarf, refilling lubrication or performing adjustments.
4. Never wear loose clothing or gloves when working near cutting area or machine arbor.
5. Always wear eye protection. Any tool can shatter.
6. Always use safety chain or strap provided with machine.
7. Always use proper tooling. Keep cutters securely fastened.
8. DO NOT use dull or broken cutters.
9. Beware of ejected slugs at end of cut. They become HOT during the cut.
10. Keep all safety features functioning and working properly.
11. Keep bottom of magnet burr free and clear of chips and debris.
12. To reduce the risk of electrical shock, DO NOT remove or alter electrical panels or use machine in damp areas.
13. Use only authorized service centers for repairs.
14. Always ensure the entire surface of the magnet base is in contact with the steel workpiece.

Remove all contents from packaging and inspect to ensure no damage was incurred during shipping. Your Holemaker package should include the following:

DESCRIPTION	QTY
HOLEMAKER PRO75 MACHINE	1
METAL CARRY CASE	1
SAFETY CHAIN WITH CLIP	1
SAFETY GUARD	1
8MM FLAT WRENCH	1
HEX WRENCH 2.5	1
HEX WRENCH 4	1
HEX WRENCH 5	1
HEX WRENCH 6	1
SPOKE HANDLE WITH KNOBS	3
#3MT ARBOR ASSEMBLY	1
COOLANT BOTTLE ASSEMBLY	1
DRILL DRIFT	1
OPERATORS MANUAL	1

Assemble three spoke handles to feed hub. NOTE: Feed hub assembly is mounted on right side of machine frame – if necessary, it can be reversed for left hand operation by simply removing the fastener and hub from frame. Remove hub pinion shaft from right side of frame and insert it into left side of frame. Replace hub and fastener into frame and tighten securely. Install the arbor into the drill motor by inserting the arbor body into the spindle. By turning the arbor while inserting, the arbor tang will properly line up in the spindle. Turn the arbor until it bottoms out in the spindle and then tap lightly with a plastic hammer to secure.

WHAT YOU SHOULD KNOW BEFORE YOU DRILL

1. Type of material to be drilled, Brinnell or Rockwell hardness, material thickness and position should all be determined to ensure proper selection of cutting tools.
2. Remove any excessive mill scale or rust from surface to be drilled.
3. When drilling thin materials, it is recommended that you place a steel plate under the work piece and Holemaker magnet area to increase magnetic holding force.
4. Material that has been flame cut may become heat treated and therefore difficult to drill. Avoid drilling near such areas whenever possible.
5. Special cutter lubricant is available for using the Holemaker and annular cutters in the horizontal position. Consult you distributor for more information.

 Caution: Do not drill on material where welding is also simultaneously being performed. Drilling machine will be damaged.

 Caution: Powering drilling machine from generator without proper surge protection device between generator and drilling machine may cause damage to the Printed Circuit Board in machine.

 The Holemaker Pro 75 is not designed for use on steel thinner than 3/8" or 10mm, as the magnet's adhesive power would be significantly reduced which can cause machines failure or individuals injury. The machines built in "Smart Magnet Technology" will detect insufficient magnetic adhesion, and will cause the machines motor on/off button to not engage. Although it is not recommended, this feature can be bypassed by following the attached "Smart Magnet Technology Bypass" instruction leaflet.

START UP AND OPERATION

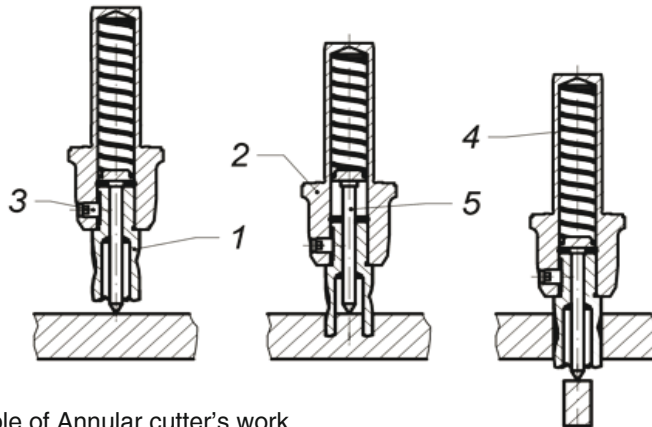
**CAUTION: READ THE WHOLE INSTRUCTIONS MANUAL
BEFORE ATTEMPTING TO START UP**

Principle of Annular cutter's work

This drilling machine's spindle has a 19mm Weldon Shank type and is specifically designed for use with Annular cutters.

Annular cutter (1) is located inside arbor body (2) and is fastened with grub screws (3). When fastening the cutter in the arbour, ensure that the grub screws are firmly tightened to avoid them coming loose during operation. It is important to position the cutter in relation to the arbour in such a way that fixing flats on the cutter shank are positioned opposite to the grub screws (3). Both grub screws(3) should be used to fasten the cutter. The Pilot Pin (5) is located inside the cutter to easily position the annular cutter over centre of a planned hole. During drilling as the cutter goes into the material, the pilot pin moves back into the arbour body and pressurizes the discharge spring (4). That spring ejects the slug which is a by-product of drilling the hole with a centre free cutter.

The machine is supplied in a metal box. Some components of the drilling machine are coated with grease film for protection during transit and storage. Prior to use of the machine this should be wiped clean.

CONTROL PANEL

Control elements include:

- Magnet Switch (1),
- Start-Stop Switch (2),
- Speed Control Dial (3),

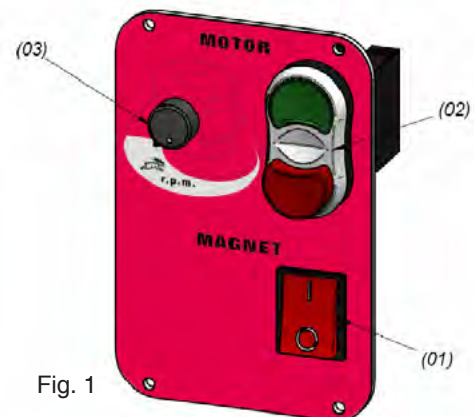

Fig. 1

- a) In order to start the machine press the magnet switch (1) on "I". Now you can start the motor by pressing Start-Stop Switch (2) green button "I"
- b) Stopping the motor is executed with red button „O” (the motor is switched OFF but the electromagnetic base is still ON).
- c) The speed at which the spindle rotates can be controlled by turning the speed control dial (3) clockwise to increase, or anti-clockwise to decrease.
- d) To move machine into next drilling spot, stop the motor as described above and push the magnet switch (1) to the position "O".

NOTE: As a power saving function, Switching the Magnet Switch(1) to "I" will supply the electromagnet with 50% power. Switching the Start-Stop Switch(2) to "I" will increase the electromagnet to 100% power.

Before you cut

Before positioning the machine on work piece always make sure that:

- work piece is made of ferrous material
- thickness of work piece is adequate for secure magnetic adhesion (mild steel - 10mm is recommended)
- Ensure no part of magnet overhangs the steel workpiece
- surface of steel under the magnet is flat
- wipe, brush or sand down clean surface where you intended to place the drilling machine, so that you remove rust, paint, dirt etc which would reduce adhesive power of the electromagnetic base.

Install annular cutter in the machine before plugging it into mains.

Place the machine so that the tool is over the centre of the hole you intend to make and turn the magnetic base ON.

Always make sure prior to use that the machine is secured from falling down with a chain/strap.



Fig. 1
An example of a safety chain/strap use.

Swivel Base Feature (optional)

The HMPRO75SR is equipped with an additional feature which allows the upper frame of the machine to move around on the magnetic base about 15 degrees and 15 mm front/back. Using the supplied 10mm allen key, loosen the socket head bolt shown in fig.2, move the machines frame to the desired position, then re-tighten socket head bolt firmly before operating machine.

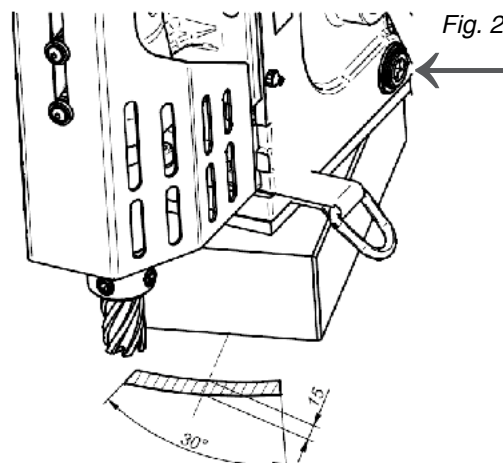

Cutting

- Choose a suitable lubricating fluid and fill the coolant tank.

The cooling system is an integral part of the machine and should always be used.

Warning: The cooling system works gravitationally, therefore it can be used only when in vertical position of the drilling machine. In other positions, a cutting paste should be used

- Check workings of cooling system. Open the coolant tank's tap and apply pressure on the pilot by turning spokes counter clockwise. As the pilot starts to sink into the cutter, cooling liquid should start to run down the groove in pilot pin. If there is no liquid flowing down, check if the tap is fully opened. It may take a few seconds for cooling liquid to fill the whole system.

- Select a suitable rpm speed range, either 80-160rpm or 210-420rpm, by moving the gear switch located on the side of the gearbox up or down. Once the speed range has been selected, the spindle speed can be controlled variably by the speed control dial as pictured on pg8 fig1 (3) Use the table below as a guide when deciding upon a speed.

The cutter diameter		Rotary speed [rpm]
[inch]	[mm]	
1.38 - 3.00	35 - 75mm	160 - 80
0.50 - 1.37	12 - 34mm	420 - 210

- Turn the motor on.

Bring the cutter gently into contact with the work piece and slowly start to apply pressure on the cutter.

Making a hole with an annular cutter should ideally be done in one pass. Do not peck drill.

WARNING : When the annular cutter goes through the material the slug can be pushed out often with considerable strength. Pay attention to avoid injury.

- After a hole is made the cutter should be retracted and both the motor and the electromagnet should be switched OFF.
- When work with the machine is finished the power cord should be disconnected from the power source, the machine should be cleaned up from swarf, coolant etc and the cutter should be removed and cleaned.

Reverse Feature (optional)

The HMPRO75SR is equipped with a forward / reverse motor. Motor rotation is controlled by using the three position rotary switch located on the control panel.

R - Forward/Clockwise

O - Neutral

L - Reverse/Counterclockwise

MAINTENANCE AND SERVICE

- Every 250 hours of work check condition of carbon brushes. If their length is less than 5 mm they should be replaced with new genuine brushes. After replacement, new brushes should be run-in without load for about 20 min. Repair and service work is to be performed by authorized service agents only.
- Keep the magnet clean and free of chips, oil or other contaminants.
- Inspect arbor, sleeve and support bracket for visible wear.
- Replace any worn parts and tighten any fasteners that may have come loose during daily usage.

CANCELLING CLEARANCE

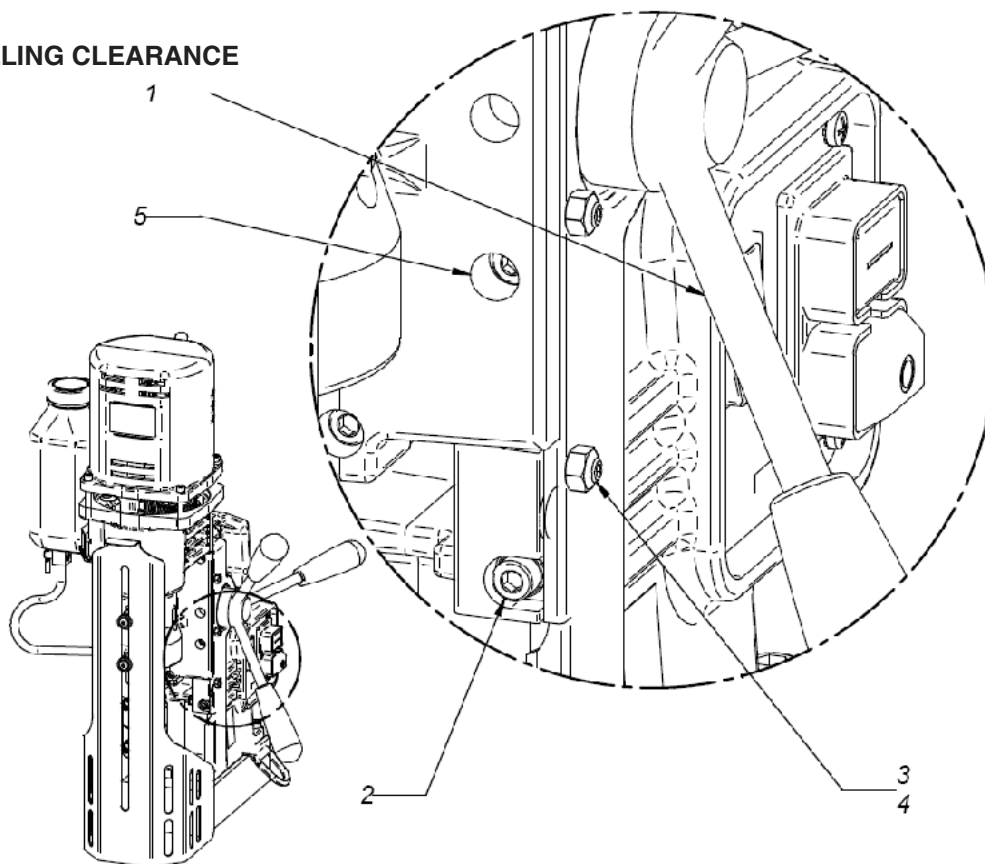

The drive and the slider can be slid up and down smoothly using the lever (1), the screws (2) fixing the strip to the drill body visible through the openings in the slider (5). To loosen screws (2), the slider should be placed in such a position (using feed handles) so that the openings make the screws visible. After loosening the screws slide the slider up and down several times so that the pressure strip aligns itself and cancels clearance.

After carrying out these steps and canceling clearance, tighten screws (2) starting from the middle screw. The slider should be located symmetrically relative to the middle screw. Next, tighten the neighboring screws (2) moving the slider in the degree necessary for making them visible. Then, tighten screws (3) until any noticeable resistance is felt. When the screw in this position and blocked with a hexagonal key, tighten counter nut (4). The screws (3) counteract the machining force and protect the pressure strip from shifting during operation.

BASIC TROUBLESHOOTING

1. Magnetic base not holding securely
 - Material is too thin.
 - Surface of material being drilled must be free of chips, debris, rust and mill scale.
 - Does size of cutter exceed machine's rated capacity?
 - Check magnet face for unevenness, nicks and burrs.

2. Drill motor running, arbor and spindle not turning
 - Possible sheared drive train component.

3. Motor slows when drilling
 - Is an extension cord being used? If so, see page 5 for recommended wire gages and cord lengths.
 - Excessive downfeed pressure during drilling cycle will cause motor to slow and overheat.
 - Does cutting tool need to be resharpened?

4. Coolant system not working
 - Coolant system is gravity dependent, machine must be in a upright position to operate properly.
 - Dirt or debris in coolant tank.
 - Consistency of coolant mixture too thick.
 - Is correct pilot pin being used?
 - Vent hole in coolant tank lid blocked.

5. Slugs not ejecting from cutter
 - Lack of coolant causing slugs to expand in cutter bore.
 - Is correct pilot pin being used?
 - Possible broken internal arbor parts.

6. Breaking cutters
 - How is coolant being applied? Coolant must be supplied to interior of cutter.
 - Excessive feed pressure being applied when cutter initially contacts work surface.
 - Confirm material hardness.
 - Drilling stacked materials with incorrect cutter.
 - Dull cutters; dull or chipped cutting edges require excessive feed pressure, resulting in breakage.
 - Movement of machine on material - See "1. Magnetic base not holding securely"
 - Inconsistent hardness in material can cause cutter breakage

7. Oversized or rough holes
 - Insufficient coolant.
 - Excessive feed pressure.
 - Dull cutter.

HMPRO75		MAGNETIC DRILLING MACHINE HOLEMAKER PRO 75	
ITEM	PART NUMBER	DESCRIPTION	QTY
1	SPPRO7501	FRAME ASSEMBLY	1
2	SPPRO7502	MOTOR COMPLETE /230V	1
3	SPPRO7503	PANEL PLATE ASSY	1
4	SPPRO7504	GUARD ASSY	1
5	SPPRO7505	PINION SHAFT ASSY	1
6	SPPRO7506	ELECTRONIC CONTROL SYSTEM /230V	1
7	SPPRO7507	SPOKE HANDLE INCLUDING KNOB (ASSY)	3
8	SPPRO7508	LOWER SLEEVE,	2
9	SPPRO7509	COOLANT SYSTEM	1
10	SPPRO7510	ARBOR ASSY AMT3-U19/3-3	1
11	SPPRO7511	POWER CORD 230V 3x1	1
11.4	SPPRO751104	STRAIN RELIEF PG11	1
12	SPPRO7512	PUSH SPRING,	2
13	SPPRO7513	SCREW M4X10 PHCRMS	1
14	SPPRO7514	EXTERNALE RETAINING RING 28z	1
15	SPPRO7515	SPRING WASHER-4.3	6
16	SPPRO7516	SPRING WASHER-4.1	5
17	SPPRO7517	NYLON WASHER SR1940,	4
18	SPPRO7518	SOCKET BUTTON HEAD CAP SCREW WITH FLANGE M5x20,	2
19	SPPRO7519	SCREW M4X12 PHCRMS	4
21	SPPRO7521	CROSS RECESSED PAN HEAD TAPPING SCREW 3,5x13	4
22	SPPRO7522	WASHER,LOCK,INTERNAL STAR 3,7	4
23	SPPRO7523	EYE BOLT M8 B	1

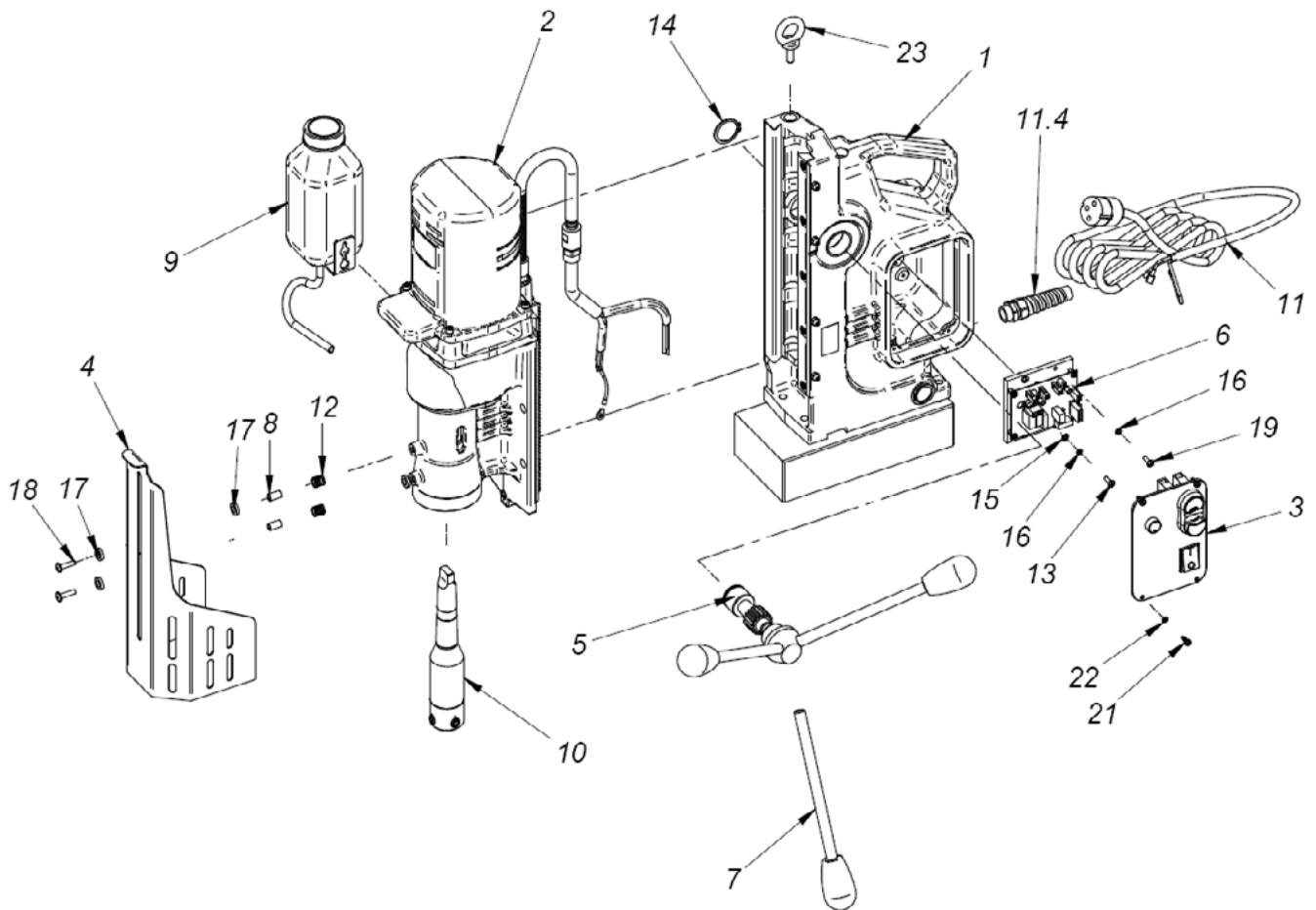

SPPRO7501		FRAME ASSEMBLY	
ITEM	PART NUMBER	DESCRIPTION	QTY
1.1	SPPRO750101	MAIN BODY ASSY	1
1.2	SPPRO750102	D-RING STRAP	1
1.3	SPPRO750103	ELECTROMAGNETIC BASE	1
1.4	SPPRO750104	SWIVEL BASE PLATE	1
1.5	SPPRO750105	CLAMPING PLATE ARM	1
1.6	SPPRO750106	ECCENTRIC SWIVEL BASE SHAFT	1
1.7	SPPRO750107	SPECIAL NUT	1
1.8	SPPRO750108	SPECIAL WASHER MT3 V2	1
1.9	SPPRO750109	SPECIAL BOLT ,	1
1.10	SPPRO750110	EXTERNAL RETAINING RING- 21Z	2
1.11	SPPRO750111	SPRING WASHER 6,1	3
1.12	SPPRO750112	SPRING WASHER 8,2	4
1.13	SPPRO750113	HEX. SOCKET BOLT M5X10	1
1.14	SPPRO750114	HEX. SOCKET BOLT M6x25	3
1.15	SPPRO750115	HEX SOCKET BOLT-M8X25	4

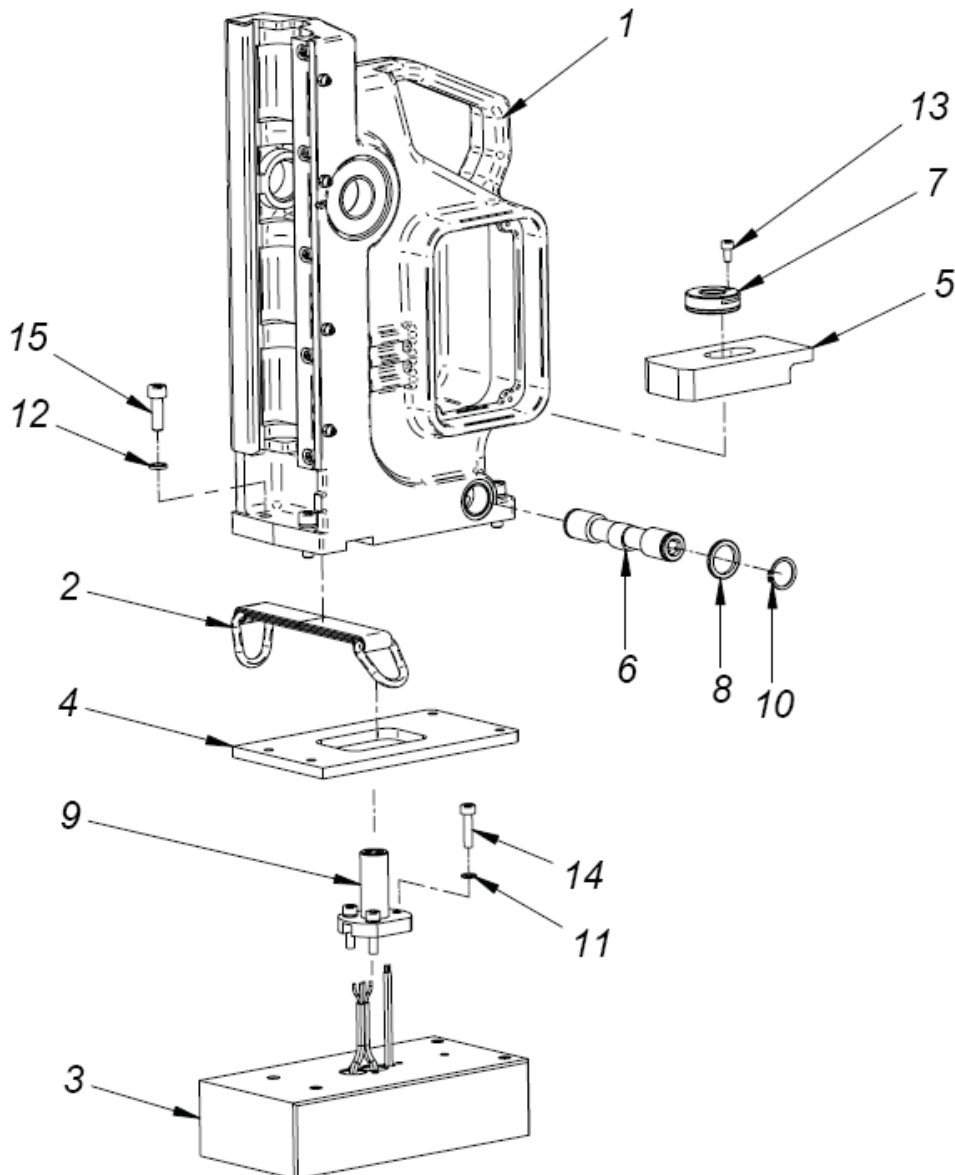

SPPRO750101		MAIN BODY ASSEMBLY	
ITEM	PART NUMBER	DESCRIPTION	QTY
1.1.1	SPPRO75010101	MAIN BODY	1
1.1.2	SPPRO75010102	PRESSURE PLATE	1
1.1.3	SPPRO75010103	SLIDE INSERT	1
1.1.4	SPPRO75010104	SELF LUBRICATING SLEEVE 28,05H7x32x16,	1
1.1.5	SPPRO75010105	SPRING WASHER	1
1.1.6	SPPRO75010106	DISC SPRING 4,2x10x0,5	1
1.1.7	SPPRO75010107	HEX SOCKET BOLT-M5X20	1
1.1.8	SPPRO75010108	ROUND WASHER 5,3	1
1.1.9	SPPRO75010109	SELF LUBRICATING SLEEVE 21H7-24-16,	1
1.1.10	SPPRO75010110	NUT M5	2
1.1.11	SPPRO75010111	SOCKET SET SCREW M5x16,	3

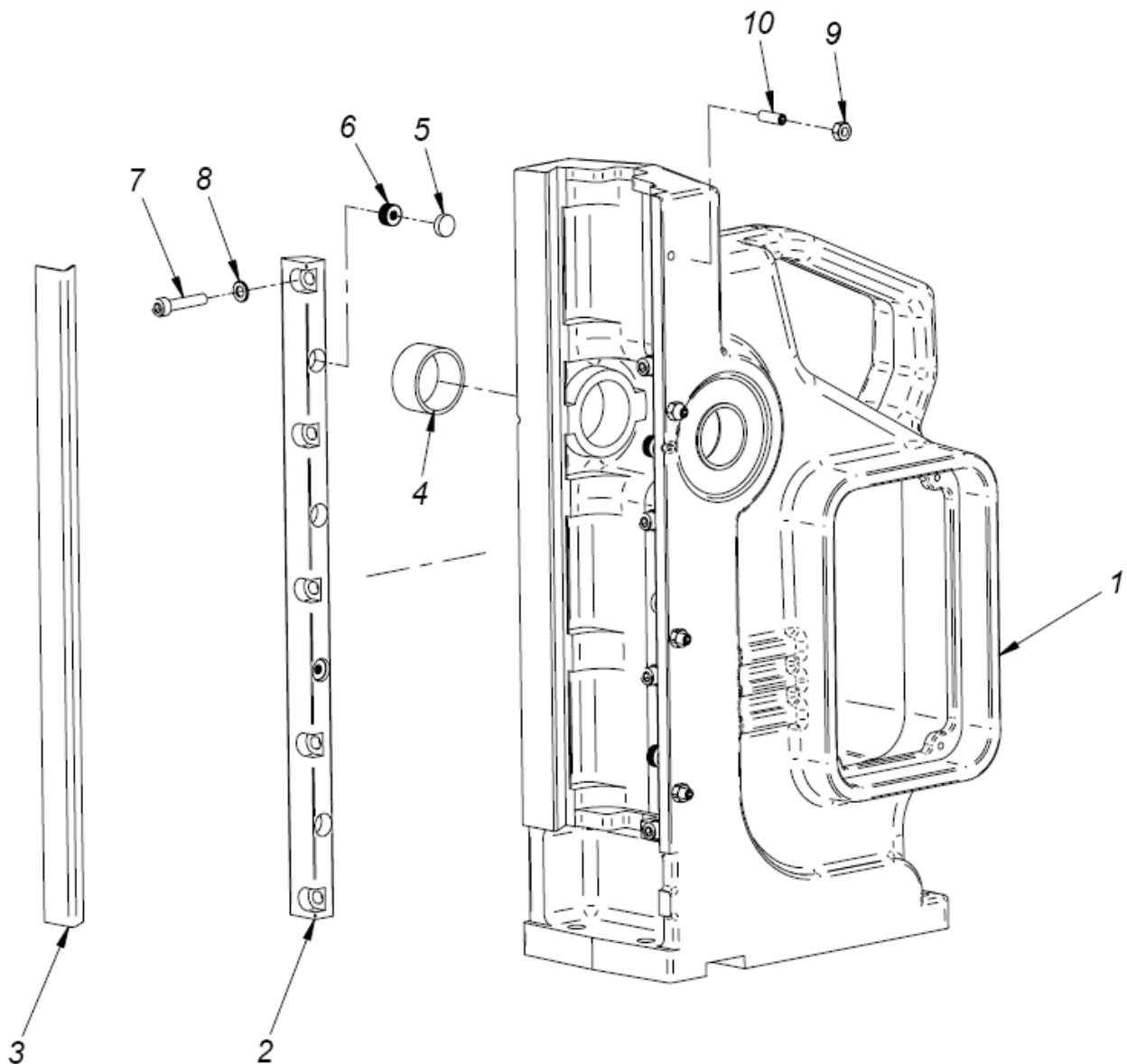

SPPRO7502		MOTOR COMPLETE 230V	
ITEM	PART NUMBER	DESCRIPTION	QTY
2.1	SPPRO750201	MOTOR ASSY/230V	1
2.2	SPPRO750202	GEARCASE ASSY	1
2.3	SPPRO750203	PINION SHAFT z12, m=1, z24, m=1 ASSY	1
2.4	SPPRO750204	PINION SHAFT z12, m=1,5 ASSY	1
2.5	SPPRO750205	MOTOR HOUSING	1
2.6	SPPRO750206	GEAR z50	1
2.7	SPPRO750207	MOTOR WIRE ASSY	1
2.8	SPPRO750208	GEAR RACK	1
2.9	SPPRO750209	ENCODER FRAME	1
2.10	SPPRO750210	ENCODER MODULE	1
2.12	SPPRO750212	NEUTRAL MOTOR WIRE ASSY	1
2.13	SPPRO750213	SHIFT PIN	1
2.14	SPPRO750214	SHIFT DRIVE PIN (USA-5)	1
2.15	SPPRO750215	COMPRESSION SPRING (USA 5)	1
2.16	SPPRO750216	SHIFT LEVER	1
2.17	SPPRO750217	IMPULSING SHIELD ASSY,	1
2.18	SPPRO750218	SHIFT FORK	1
2.19	SPPRO750219	LABEL, SHIFT LEVER	1
2.20	SPPRO750220	EXTERNALE RETAINING RING 25z	1
2.21	SPPRO750221	KEY 6x6x20	1
2.22	SPPRO750222	SPRING PIN 3x12	1
2.23	SPPRO750223	SPRING WASHER 5.1	5
2.24	SPPRO750224	SCREW M3x5 PHCRMS	2
2.25	SPPRO750225	SCREW M4X10 PHCRMS	4
2.26	SPPRO750226	SPRING WASHER-4.3	1
2.27	SPPRO750227	SPRING WASHER 6,1	2
2.28	SPPRO750228	HEX SOCKET BOLT M5x35 ,	1
2.29	SPPRO750229	HEX. SOCKET BOLT M5x50	4
2.30	SPPRO750230	HEX SOCKET BOLT-M6X25	1
2.31	SPPRO750231	HEX SOCKET BOLT-M4X10	1
2.32	SPPRO750232	CROSS RECESSED PAN HEAD TAPPING SCREW 2,5x8	2
2.33	SPPRO750233	HEX. SOCKET BOLT M-6X30	1

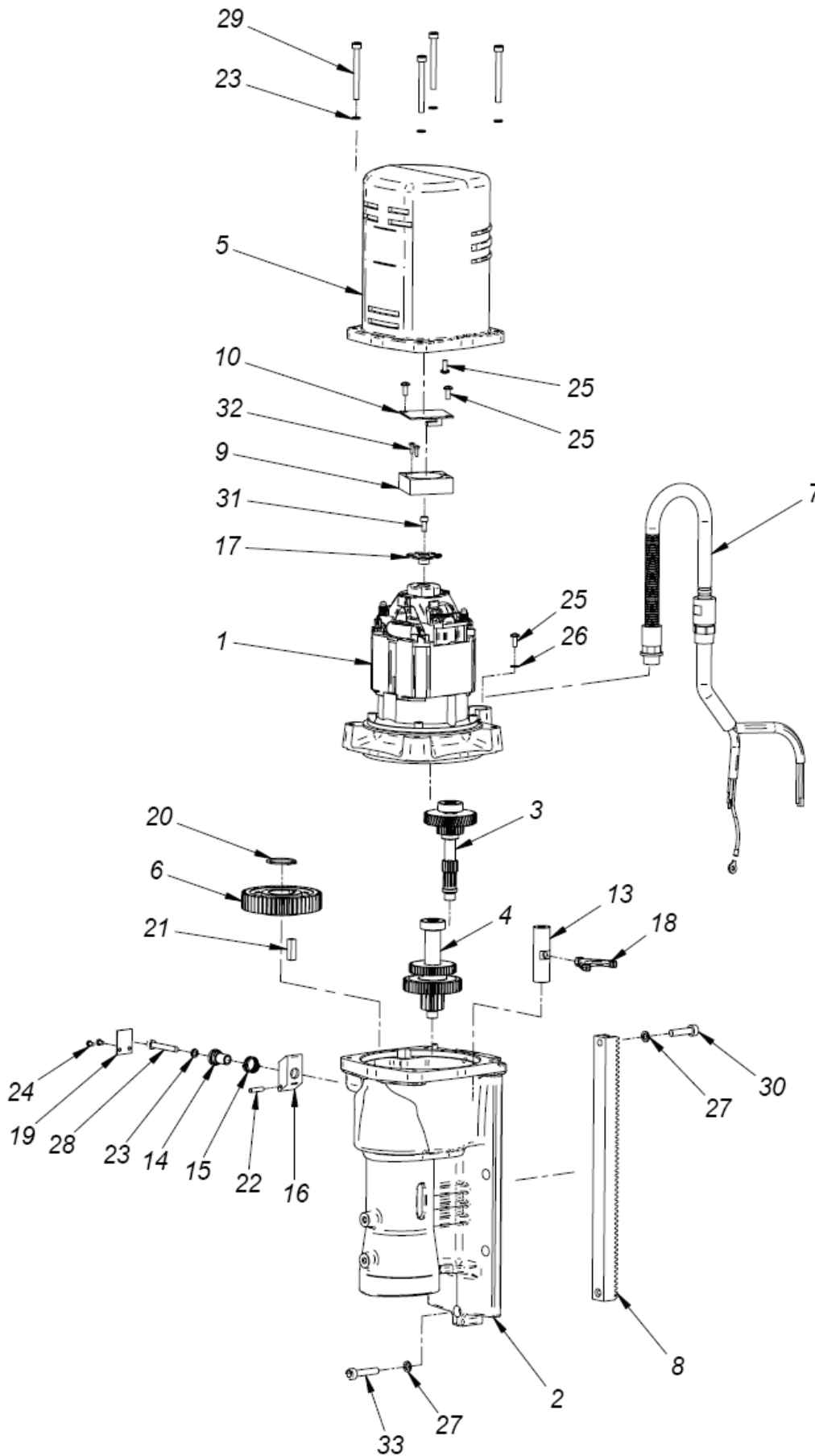

SPPRO750201		MOTOR 230V	
ITEM	PART NUMBER	DESCRIPTION	QTY
2.1.1	SPPRO75020101	MOTOR COVER	1
2.1.2	SPPRO75020102	GUIDE FAN	1
2.1.3	SPPRO75020103	ARMATURE ASSY /230V	1
2.1.4	SPPRO75020104	ARMATURE TOOTH END z8	1
2.1.5	SPPRO75020105	FIELD /230V	1
2.1.6	SPPRO75020106	UPPER HOUSING	1
2.1.7	SPPRO75020107	CROSS RECESSED PAN HEAD TAPPING SCREW 4x16	4
2.1.8	SPPRO75020108	SPRING WASHER	1
2.1.9	SPPRO75020109	BRUSH /230V	2
2.1.10	SPPRO75020110	SPRING BRUSH	2
2.1.11	SPPRO75020111	HEXAGON BOLT M4X73	2

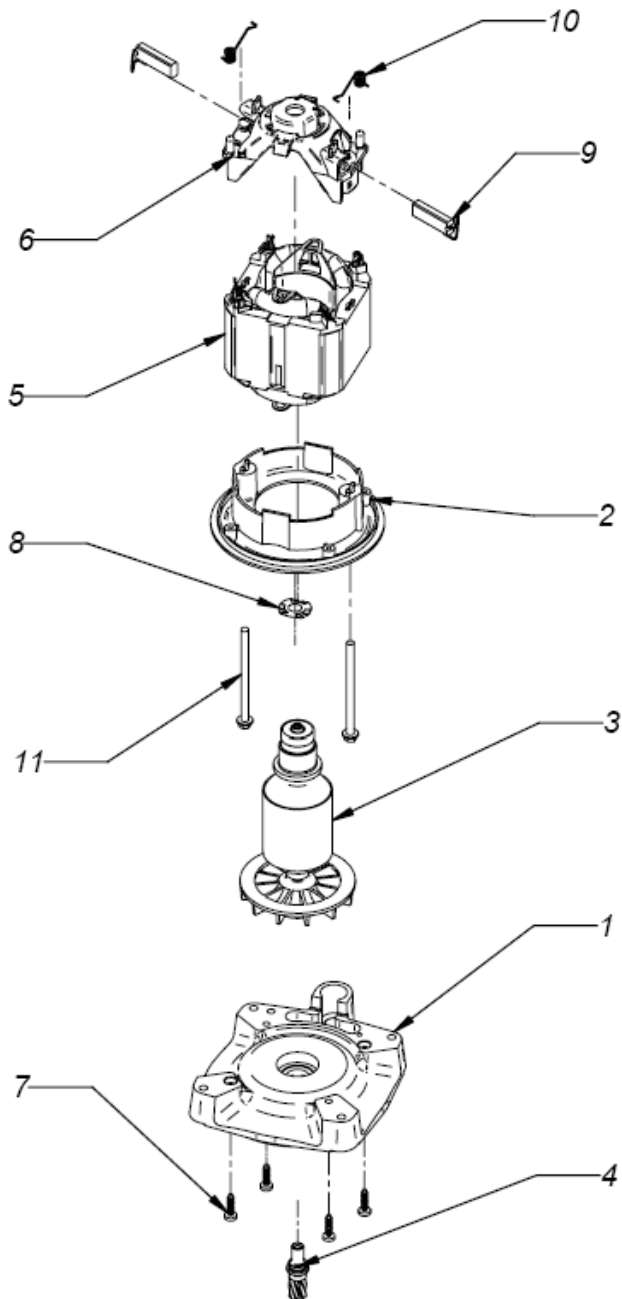

SPPRO750202		GEARBOX	
ITEM	PART NUMBER	DESCRIPTION	QTY
2.2.1	SPPRO75020201	GEARCASE	1
2.2.2	SPPRO75020202	SPINDLE	1
2.2.3	SPPRO75020203	COOLANT COUPLING AMT2-H-19	1
2.2.4	SPPRO75020204	UPPER SPINDLE BEARING 6000 2Z P6 S 10x26x8,	2
2.2.5	SPPRO75020205	UPPER SPINDLE BEARING 6007 ZZ 35x62x14,	1
2.2.6	SPPRO75020206	BEARING 6205 LLU 25x51x15	1
2.2.7	SPPRO75020207	SEAL 35x55x10	1
2.2.8	SPPRO75020208	SEAL 35x56x12	1
2.2.9	SPPRO75020209	EXTERNAL RETAINING RING- 35Z	1
2.2.10	SPPRO75020210	INTERNAL RETAINING RING 62W	1
2.2.11	SPPRO75020211	DOWEL, PIN 5 x 12 MM	1
2.2.12	SPPRO75020212	CROSS RECESSED RAISED COUNTERSUNK HEAD SCREW M5x10	2

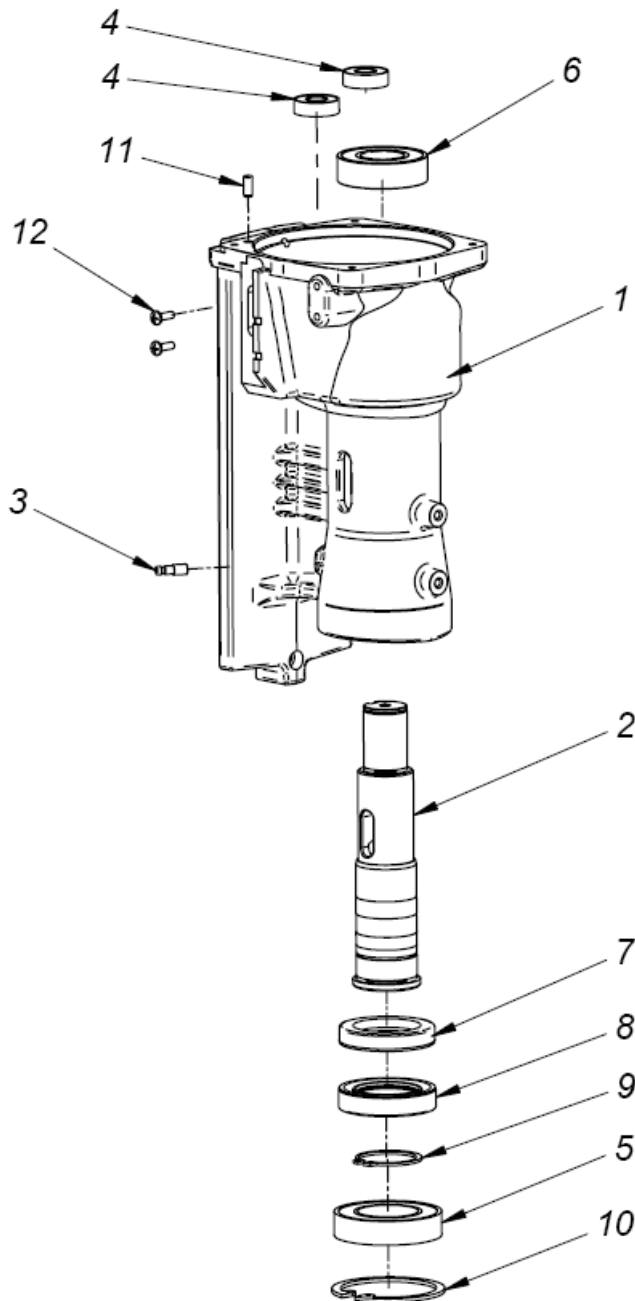

SPPRO750203		PINION SHAFT z12, m=1, z24, m=1 ASSEMBLY	
ITEM	PART NUMBER	DESCRIPTION	QTY
2.3.1	SPPRO75020301	PINION SHAFT z12, m=1, z24, m=1	1
2.3.2	SPPRO75020302	HELICAL INPUT GEAR z47, m=1, m=17	1
2.3.3	SPPRO75020303	WOODRUFF KEY 3x3.7	1
2.3.4	SPPRO75020304	UPPER SPINDLE BEARING 628 2Z NTN 8x24x8	1

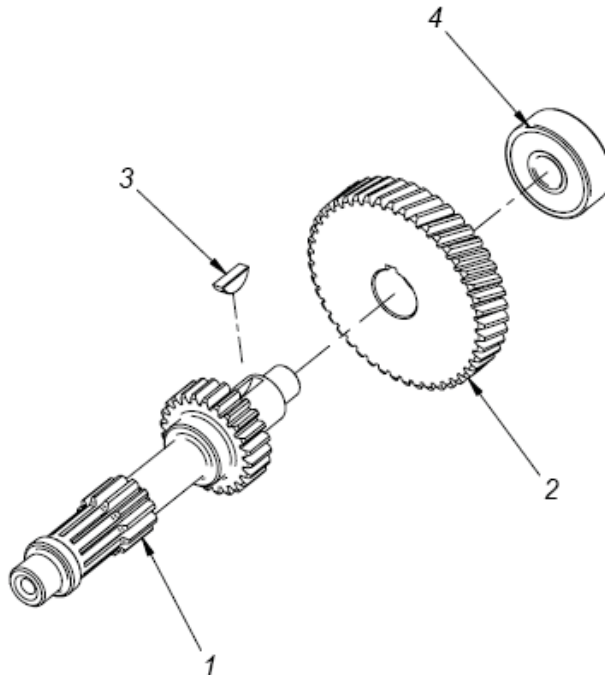

SPPRO750204		PINION SHAFT z12, m=1,5 ASSEMBLY	
ITEM	PART NUMBER	DESCRIPTION	QTY
2.4.1	SPPRO75020401	PINION SHAFT z12, m=1,5	1
2.4.2	SPPRO75020402	SHIFT WHEEL z=43	1
2.4.3	SPPRO75020403	KEY 4x4x45	1
2.4.4	SPPRO75020403	UPPER SPINDLE BEARING 628 2Z NTN 8x24x8,	1

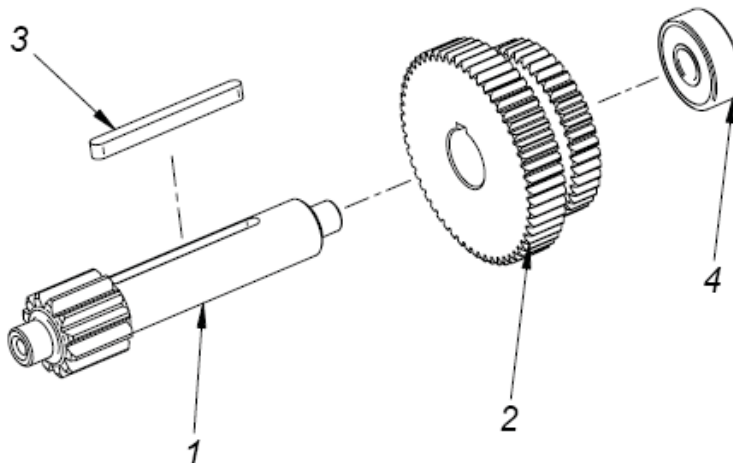

SPPRO7503		PANEL PLATE ASSEMBLY	
ITEM	PART NUMBER	DESCRIPTION	QTY
3.1	SPPRO750301	PANEL PLATE	1
3.3	SPPRO750303	SWITCH START-STOP,	1
3.4	SPPRO750304	START-STOP WIRE,	1
3.5	SPPRO750305	SWITCH MAGNET	1
3.6	SPPRO750306	R.P.M WIRE	1

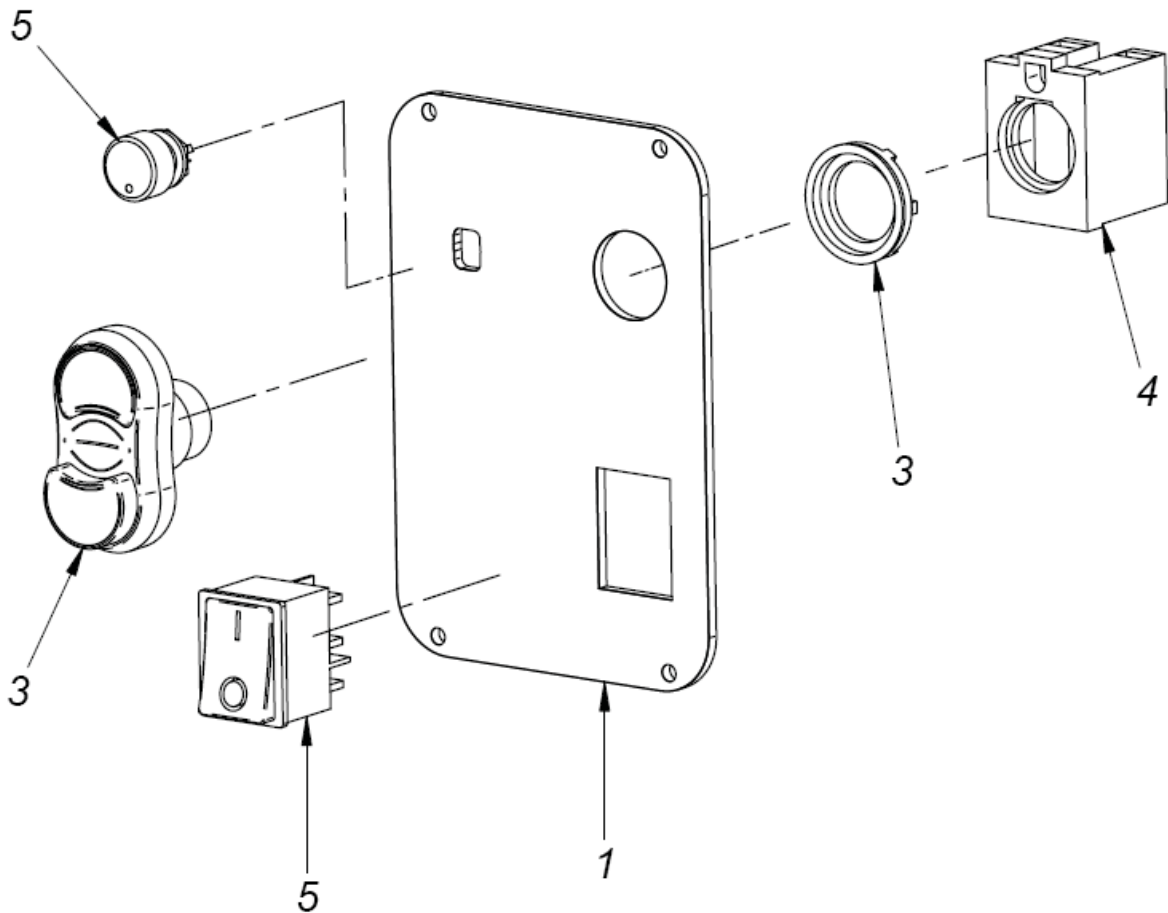

ELECTRICAL DIAGRAM

