

HOLEMAKER HMSPECIAL60

Holemaker Portable Magnetic Drilling Machine

OPERATOR'S MANUAL

⚠ WARNING!

BEFORE USE, ENSURE EVERYONE USING THIS MACHINE READS AND UNDERSTANDS ALL SAFETY AND OPERATING INSTRUCTIONS IN THIS MANUAL .



EYE PROTECTION
REQUIRED



HEARING PROTECTION
REQUIRED



NEVER PLACE
FINGERS NEAR
CUTTING AREA OR
MACHINE ARBOR

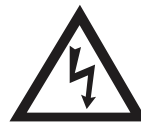

LINE VOLTAGE
PRESENT



BEWARE OF
ROTATING
MACHINE PARTS

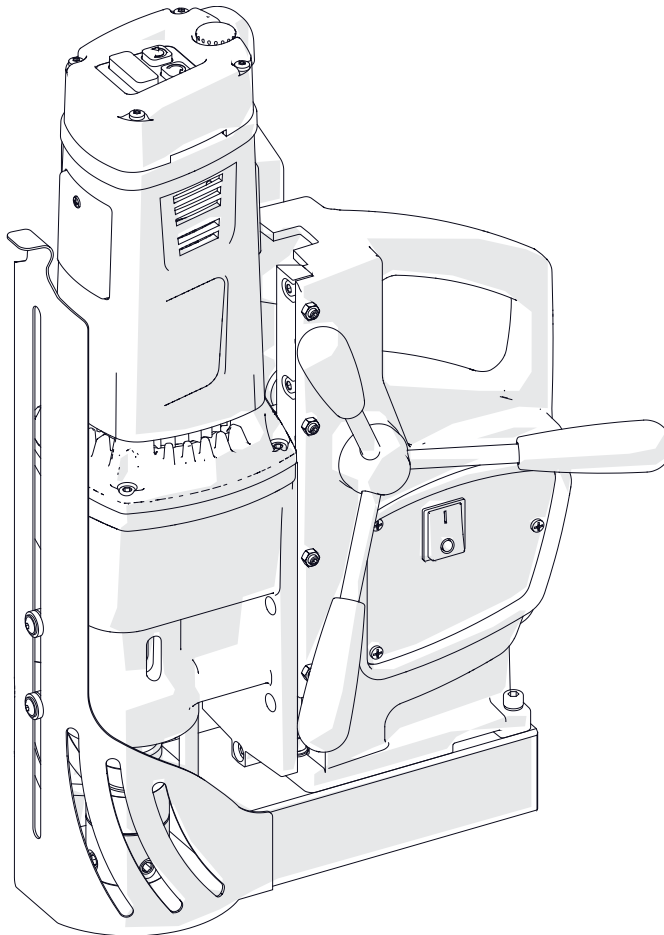

Serial # _____

Date of Purchase _____

LIMITED WARRANTY

Industrial Tool & Machinery Sales (hereinafter referred to as ITMS) will, within twelve (12) months from the original date of purchase, repair or replace any goods found to be defective in materials or workmanship. This warranty is void if the item has been damaged by accident, neglect, improper service or other causes not arising out of defects in materials or workmanship. This warranty does not apply to machines and/or components which have been altered, changed, or modified in any way, or subjected to overloading or use beyond recommended capacities and specifications. Worn componentry due to normal wear and tear is not a warranty claim. Goods returned defective shall be returned prepaid freight to ITMS or agreed repair agent, which shall be the buyer's sole and exclusive remedy for defective goods. ITMS accepts no additional liability pursuant to this guarantee for the costs of travelling or transportation of the product or parts to and from ITMS or the service agent or dealer, such costs are not included in this warranty.

Our goods come with guarantees which cannot be excluded under the Australian Consumer Law. You are entitled to replacement or refund for a major failure and to compensation for other reasonably foreseeable loss or damage. You are also entitled to have the goods repaired or replaced if the goods fail to be of acceptable quality and the failure does not amount to a major failure.

THE MANUFACTURER RESERVES THE RIGHT TO MAKE IMPROVEMENTS AND MODIFICATIONS TO DESIGN WITHOUT PRIOR NOTICE.

PRODUCTS IMPORTED AND DISTRIBUTED NATIONALLY BY:



INDUSTRIAL TOOL & MACHINERY SALES

18 BUSINESS ST, YATALA QLD 4207

T: 07 3287 1114 E: sales@industrialtool.com.au

F: 07 3287 1115 W: www.industrialtool.com.au

Contents

1. GENERAL INFORMATION	3
1.1. Application	3
1.2. Technical data.....	3
1.3. Equipment included	4
1.4. Dimensions	5
1.5. Design	6
2. SAFETY PRECAUTIONS.....	7
3. STARTUP AND OPERATION	9
3.1. Installing the handles	9
3.2. Installing and removing the arbor, MT2 twist drill bit, or tap chuck.....	10
3.3. Installing and removing the annular cutter.....	12
3.4. Installing and removing the screw tap	13
3.5. Installing and removing the cooling system	14
3.6. Preparing	15
3.7. Drilling.....	17
3.8. Thread cutting.....	20
3.9. Adjusting the gibs.....	21
3.10. Replacing the motor brushes.....	22
4. WIRING DIAGRAMS	23
4.1. Electronic control unit ass	23
4.1. Wiring diagram.....	24
5. PARTS LIST	25

1. GENERAL INFORMATION

1.1. Application

The HMSPECIAL60 is a drilling machine designed to drill holes with diameters of up to 60 mm by using annular cutters. The machine can also drill holes with diameters of up to 23 mm by using twist drill bits.

The machine can change the direction of rotation. This allows thread cutting by using a tap chuck.

The electromagnetic base clamps the machine to ferromagnetic surfaces. This makes sure that the operator is safe and the machine works correctly. A safety strap protects the machine from falling in case of a clamping loss.

Accessories allow you to drill in pipes, cut threads, and clamp the machine to flat non-ferromagnetic surfaces.

1.2. Technical data

Voltage	1~ 220–240 V, 50–60 Hz 1~ 110–120 V, 50–60 Hz
Power	1600 W
Spindle shank	MT2
Tool holder	19 mm (3/4") Weldon
Maximum drilling diameter with an annular cutter	60mm
Maximum drilling diameter with a twist drill bit	23mm
Maximum drilling depth	75mm*
Maximum tap size	M20 (3/4")
Clamping force (surface with the thickness of 25 mm and roughness $R_a = 1.25$)	11,000 N
Electromagnetic base dimensions	90 mm × 180 mm × 48 mm 3.5" × 7.1" × 1.9"
Stroke	190 mm (7.5")
Rotational speed under load	160–250 rpm 390–580 rpm
Minimum workpiece thickness	8 mm (0.3")
Protection class	I
Noise level	More than 85 dB
Required ambient temperature	0–40°C (32–104°F)
Weight	17 kg (37.5 lbs)

* To drill to a depth of more than 51 mm (2") with an annular cutter, use a long MT2 arbor (UCW-0220-00-00-4).

1.3. Equipment included

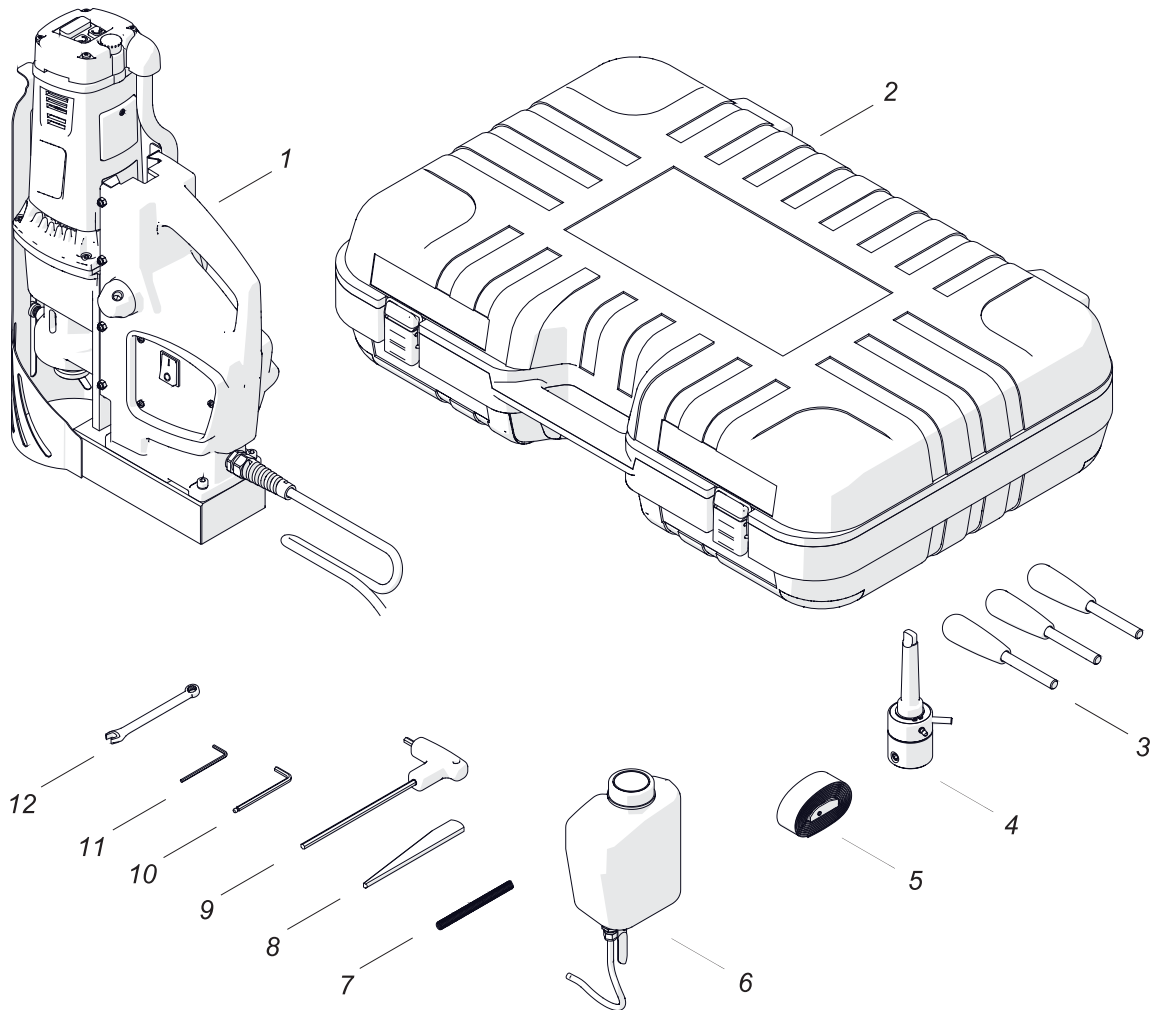

1	Drilling machine	1 unit
2	Plastic box	1 unit
3	Handle	3 units
4	MT2 arbor with 19 mm (3/4") Weldon tool holder	1 unit
5	Safety strap	1 unit
6	Cooling system	1 unit
7	Protective spring for cooling hose	1 unit
8	MT2 drift	1 unit
9	5 mm hex wrench with a handle	1 unit
10	4 mm hex wrench	1 unit
11	2.5 mm hex wrench	1 unit
12	8 mm combination wrench	1 unit
–	Operator's Manual	1 unit

1.4. Dimensions

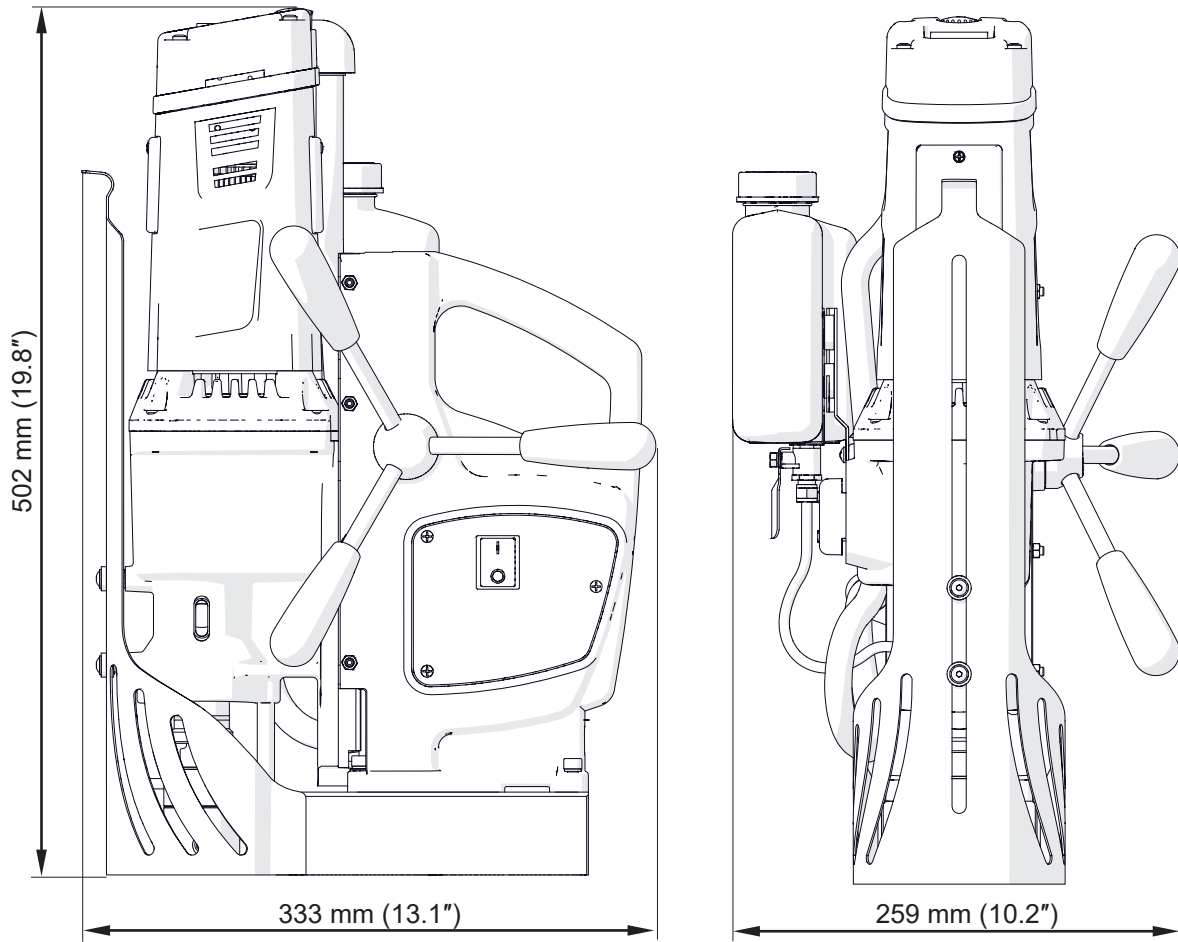

1.5. Design

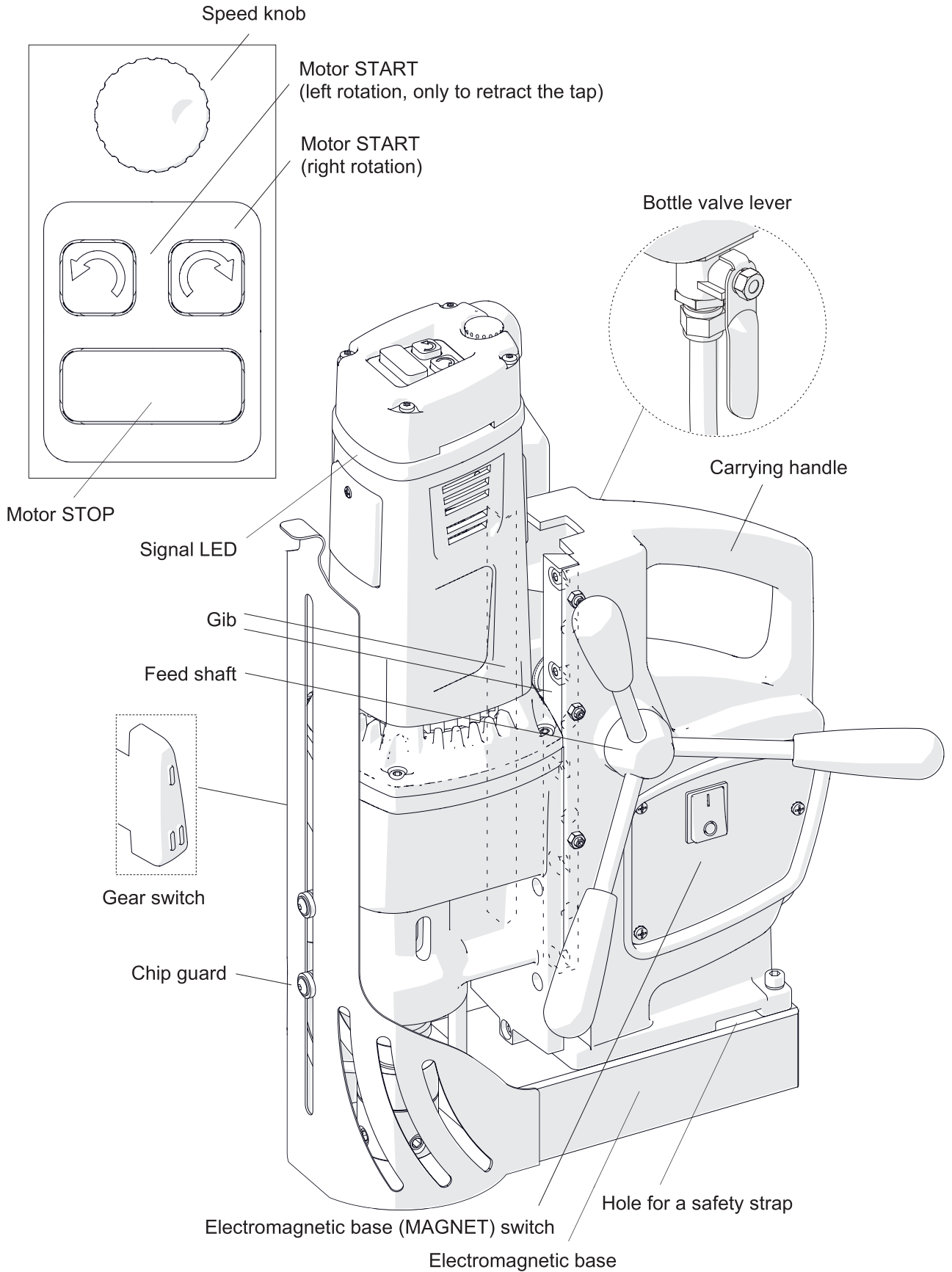

2. SAFETY PRECAUTIONS

1. Before use, read this Operator's Manual and complete a training in occupational safety and health.
2. Use only in applications specified in this Operator's Manual.
3. Make sure that the machine has all parts and they are genuine and not damaged.
4. Make sure that the specifications of the power source are the same as those specified on the rating plate.
5. Connect the machine to a correctly grounded power source. Protect the power source with a 16 A fuse for 230 V or a 32 A fuse for 115 V. If you are going to work on building sites, supply the machine through an isolation transformer with class II protection only.
6. Set the MAGNET switch to 'O' before you move the machine. Use carrying handle to move the machine.
7. Do not carry the machine by the power cord and do not pull the cord. This can cause damage and electric shock.
8. Keep untrained bystanders away from the machine.
9. Before each use, ensure the correct condition of the machine, power source, power cord, plug, control panel, and tools.
10. Before each use, make sure that no part is cracked or loose. Make sure to maintain correct conditions that can have an effect on the operation of the machine.
11. Keep the machine dry. Do not expose the machine to rain, snow, or frost.
12. Do not stay below the machine that is put at heights.
13. Keep the work area well lit, clean, and free of obstacles.
14. Make sure that the tool is correctly attached. Remove wrenches from the work area before you connect the machine to the power source.
15. Do not use tools that are dull or damaged.
16. Unplug the power cord before you install and remove tools. Use protective gloves to install and remove tools.
17. Unplug the power cord before you manually turn the spindle.
18. Use annular cutters without the pilot pin only when you drill incomplete through holes. Do not use arbors without a spring.
19. Do not make holes/threads whose diameter or depth differ from those specified in the technical data.
20. Do not use near flammable materials or in explosive environments.

21. Do not use on surfaces that are rough, not flat, not rigid, or have rust, paint, chips, or dirt.
22. Do not use if the gibs are adjusted incorrectly.
23. Do not use if there is no grease on the gibs.
24. Do not use the gear switch if the motor is on.
25. Use the safety strap to attach the machine to a stable structure. Put the strap through the hole in the machine body. In the horizontal position, attach the strap to the carrying handle. Do not put the strap into the buckle from the front.
26. Use eye and ear protection and protective clothing. Do not use loose clothing.
27. Be careful on workpieces thinner than 10 mm (0.4"). The clamping force depends on the workpiece thickness and is much lower for thin plates.
28. Each time before you put the machine on the workpiece, rub the workpiece with coarse-grained sandpaper. Make sure that the bottom of the base is in full contact with the workpiece.
29. Do not touch chips or moving parts. Do not let anything catch in moving parts.
30. After each use, remove chips and coolant from the machine and the tool. Do not remove chips with bare hands.
31. Unplug the power cord before you do maintenance or install/remove parts.
32. Repair only in a service center appointed by the seller.
33. If the machine falls, is wet, or has any damage, stop the work and immediately send the machine to the service center for check and repair.
34. Do not leave the machine when it operates.
35. If you are not going to use the machine, remove the tool from the holder. Then, remove the machine from the work area and keep it in a safe and dry place.
36. If you are not going to use the machine for an extended period, put anti-corrosion material on the steel parts.

3. STARTUP AND OPERATION

3.1. Installing the handles

Attach the handles to the feed shaft. You can install the shaft so that the handles are on the opposite side of the machine. To do this, lift the motor to the maximum and continue in the sequence that follows.

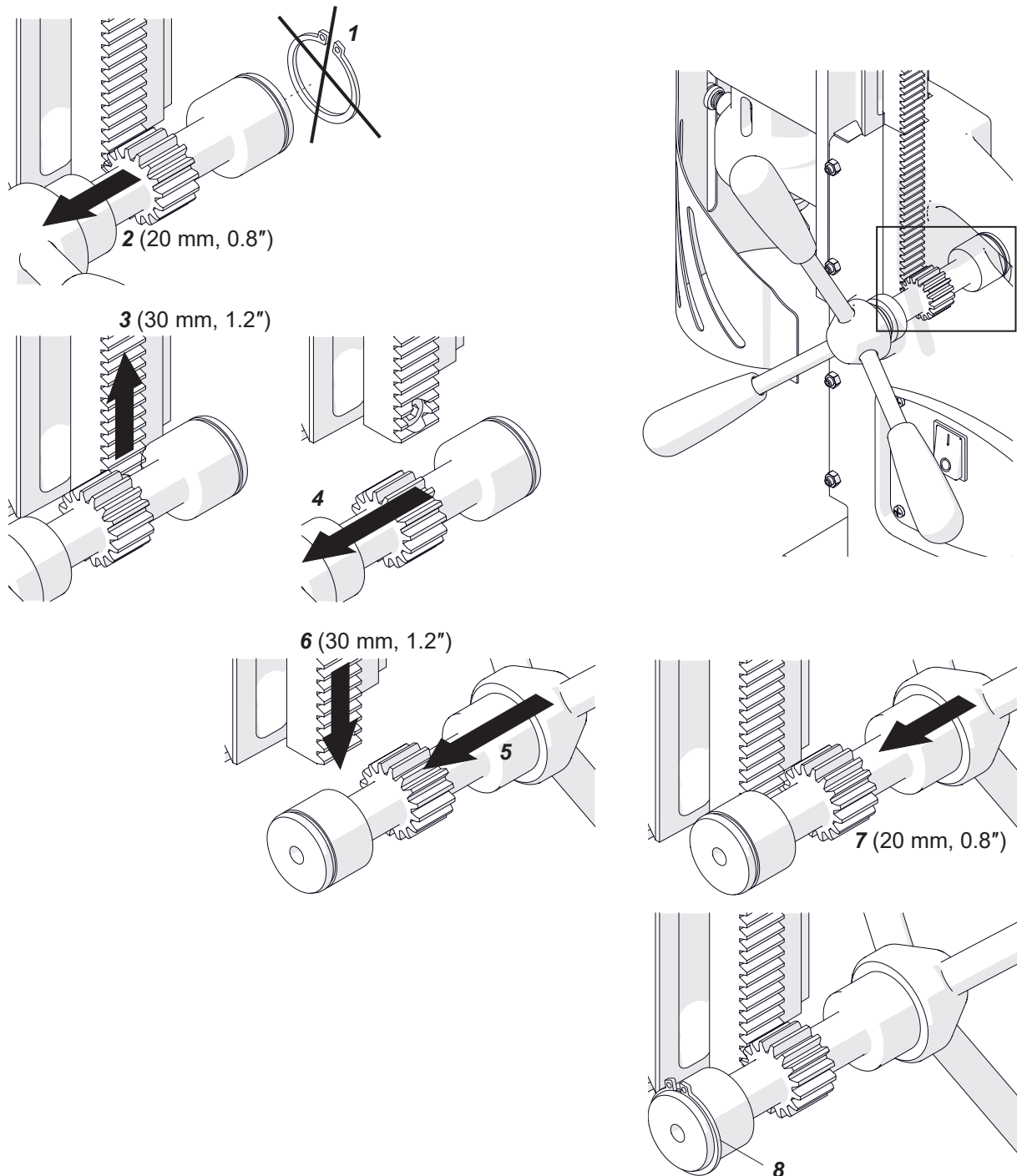

3.2. Installing and removing the arbor, MT2 twist drill bit, or tap chuck

Unplug the power cord and lift the chip guard (1). Turn the handles to the right (2) to lift the motor. Use a dry cloth to clean the spindle and the arbor (drill bit, tap chuck). Use gloves to put the arbor (drill bit, tap chuck) into the spindle (3). Make sure that the stop rod is between the pin and the fitting (4). If the arbor (tap chuck) has a nut (5), tighten the nut to the spindle.

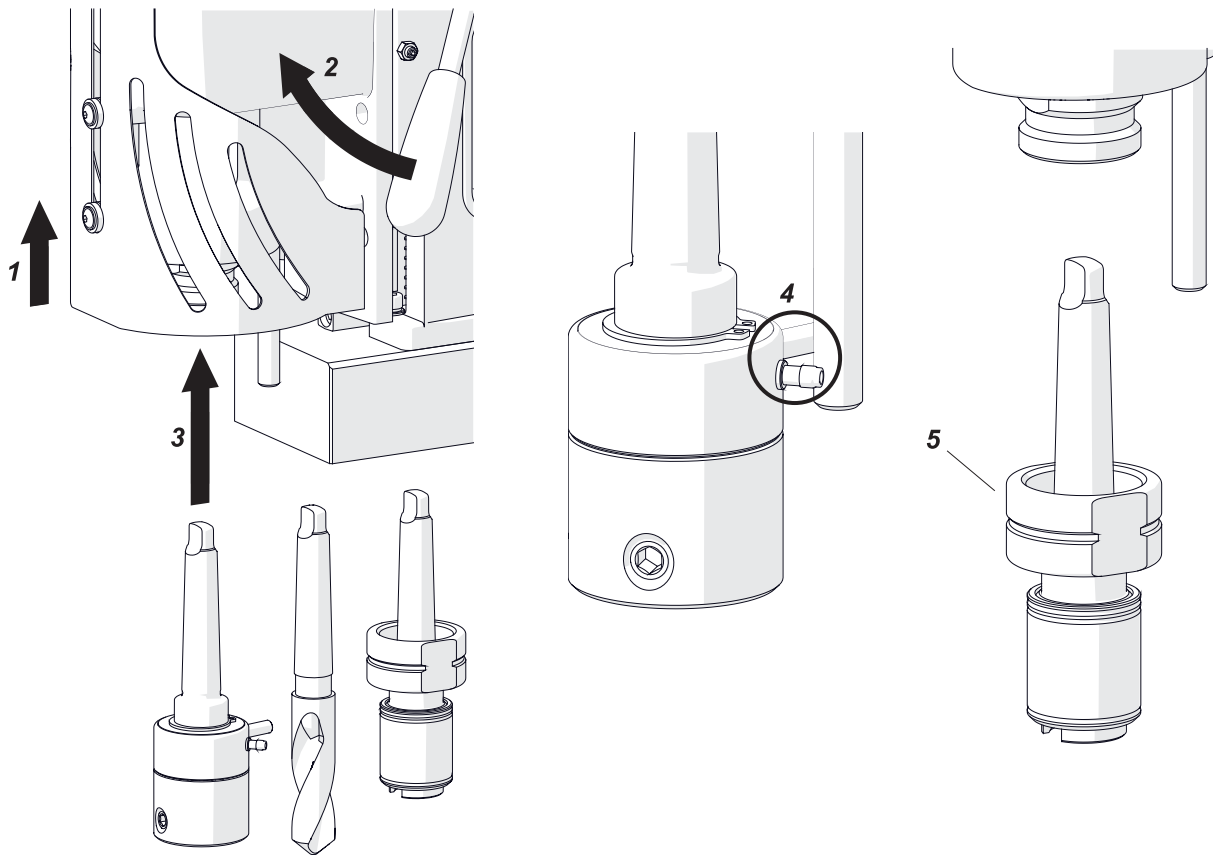

To remove the arbor (drill bit, tap chuck), continue as follows. If the arbor (tap chuck) has a nut (1), remove the nut. Next, lift the motor and turn the spindle (2) to align the holes in the spindle and gearbox (3). Put the drift into the hole (4). Next, hold the carrying handle with one hand and hit the drift with a mallet (5).

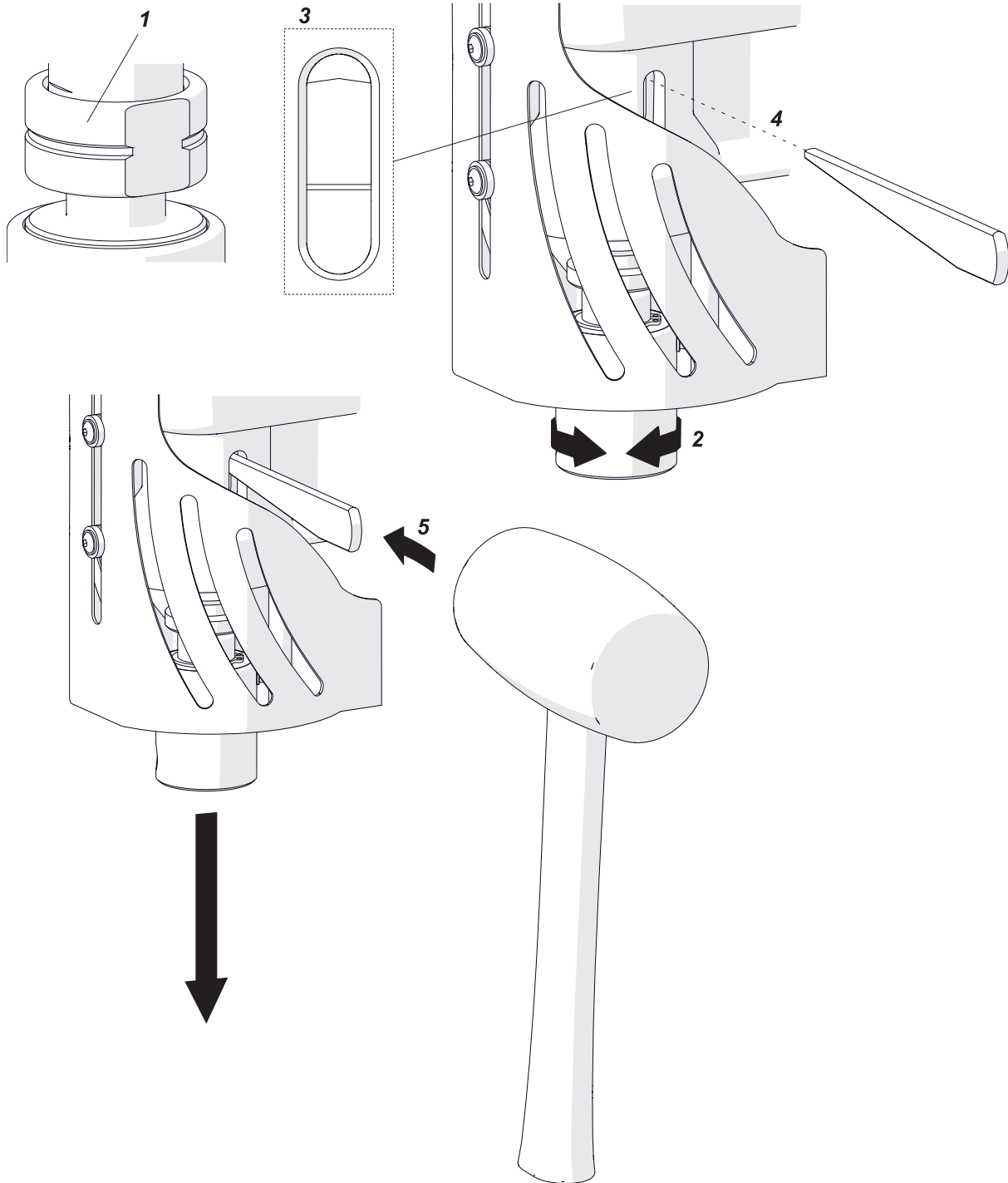

3.3. Installing and removing the annular cutter

Install the arbor as described before. Use gloves to put the correct pilot pin into the annular cutter (1). Use a dry cloth to clean the cutter. Put the cutter into the arbor (2) to align the flat surfaces (3) with the screws (4). Use the 5 mm hex wrench to tighten the screws.

To remove the cutter, loosen the screws (4) with the 5 mm hex wrench.

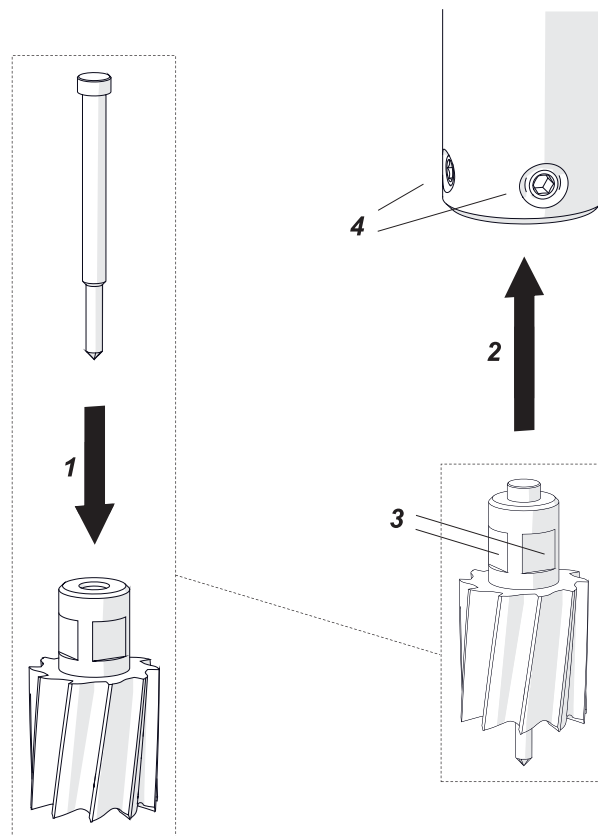

3.4. Installing and removing the screw tap

Install the tap chuck as described before. Next, put the screw tap into the correct adapter (1). Install the adapter into the tap chuck (2).

To remove the screw tap, unlock it and remove from the adapter.

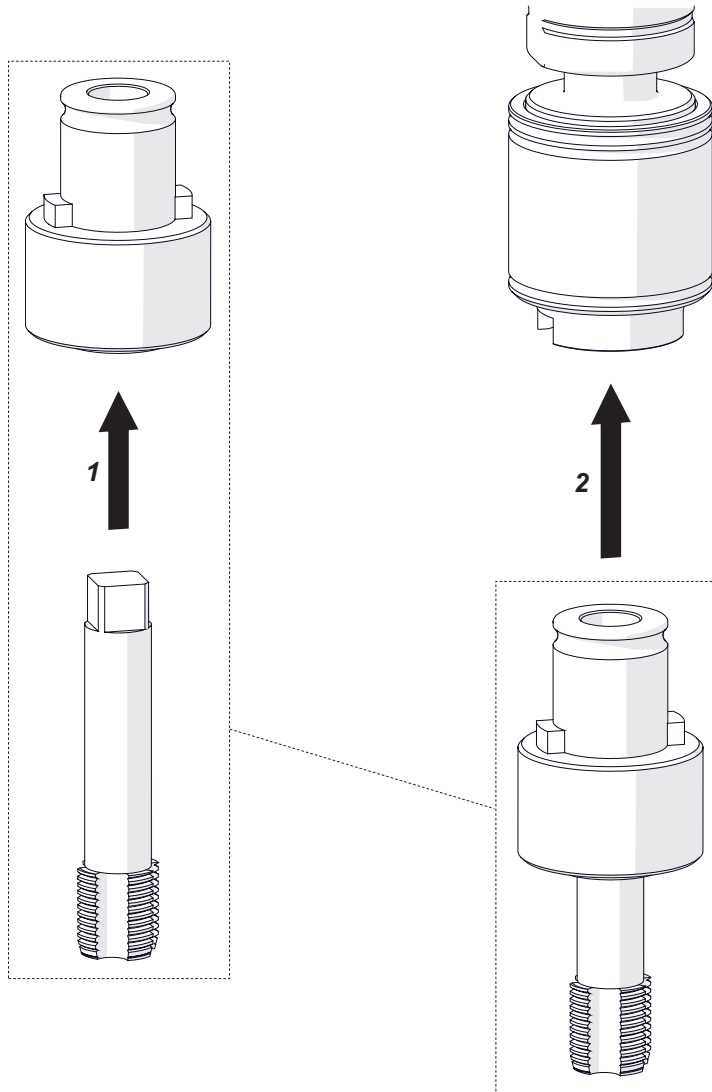

3.5. Installing and removing the cooling system

Attach the bottle to the bracket (1). Put the hose with the spring (2) between the stop rod and the body (3). Then, attach the hose to the fitting and move the spring to the arbor (4, 5).

To remove the bottle, continue in reverse sequence.

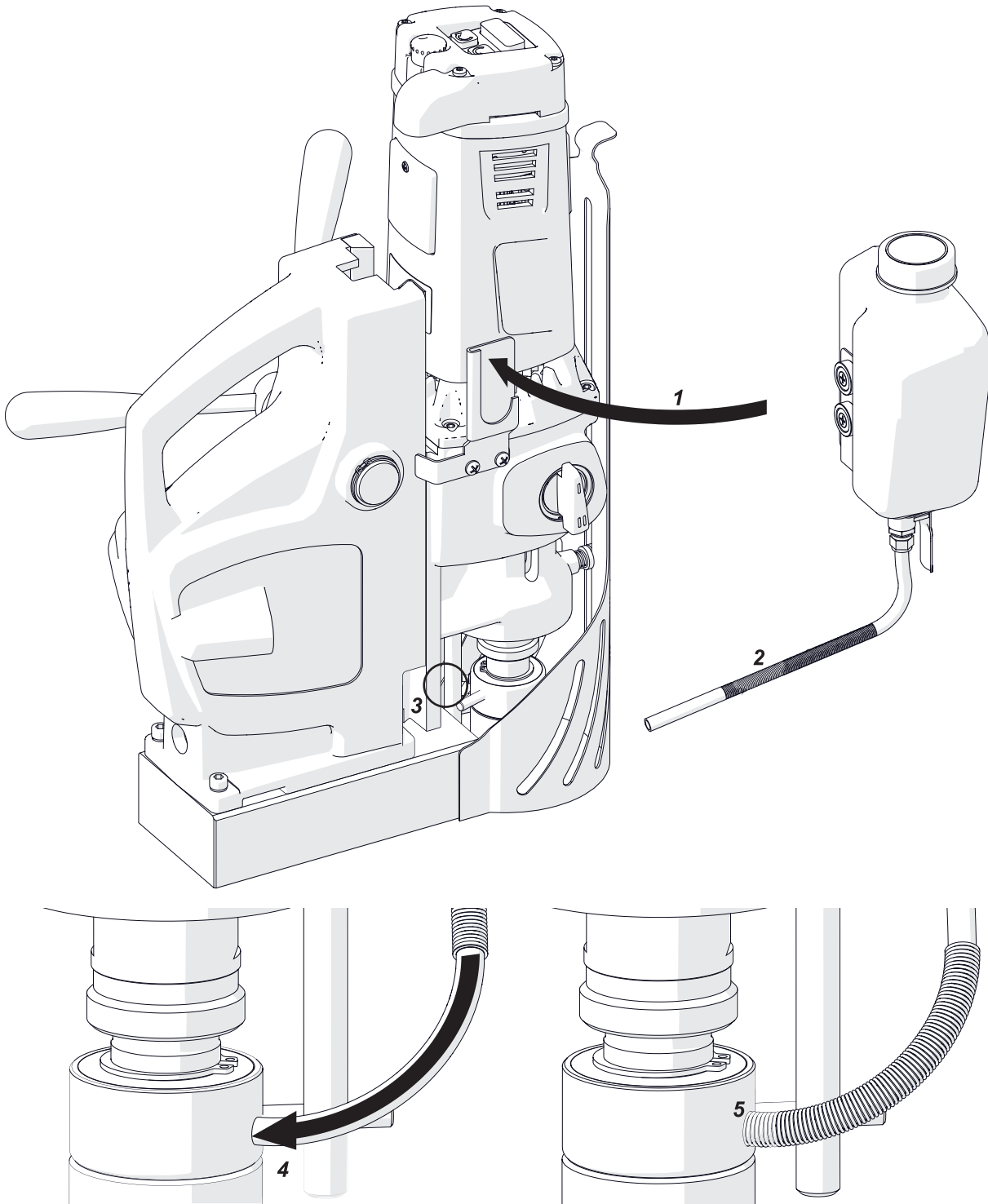

3.6. Preparing

Before use, clean steel parts, including the MT2 socket, from anti-corrosion material used to preserve the machine for storage and transport.

Attach the handles to the feed shaft. You can install the shaft so that the handles are on the opposite side of the machine.

Apply a thin layer of grease to the gibs.

Select the annular cutter, drill bit, or screw tap that matches the required hole diameter. When you drill holes with diameters of 18–23 mm (0.71–0.91") by using twist drill bits, select two bits: with 70% and 100% of the required diameter.

Use a dry cloth to clean the spindle, arbor (drill bit, tap chuck), and cutter. Then, as described before, install the arbor (and then the cutter), drill bit with the smaller diameter, or tap chuck (and then the screw tap with adapter).

Put the machine on a flat ferromagnetic workpiece with the thickness of at least 8 mm (0.3"). Make sure that there is no rust, paint, chips, or dirt. They decrease the clamping force. The force will be lower also if the surface is thin, rough, not flat, not rigid, the voltage is lower than required, or the bottom of the base is worn.

Connect the machine to the power source. Set the MAGNET switch to 'I' to turn on the clamping. Some types of steel (non-ferromagnetic) do not conduct magnetic flux so the machine cannot clamp onto them.

Use the safety strap to prevent fall and injury if the machine loses the clamping. Attach the machine to a stable structure by putting the strap through the hole in the machine body. In the horizontal position, attach the strap to the carrying handle. Make sure that the strap is tight and not twisted. If the machine comes loose from the workpiece and hangs on the strap, replace the strap. Do not put the strap into the buckle from the front.

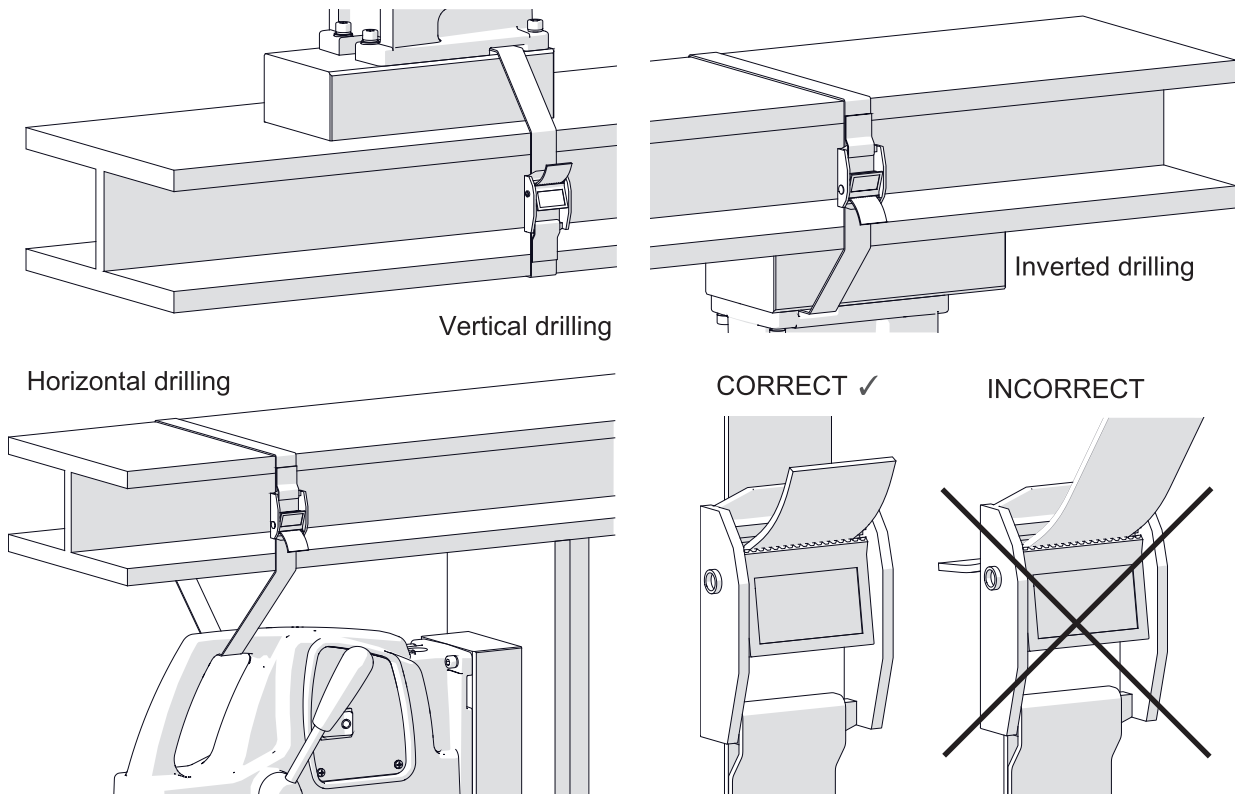





Turn the handles to the left to put the tool above the workpiece.

When you use an annular cutter, install the cooling system and fill it with coolant. Do not use only water as the coolant. But you can mix water and drilling oil. Then, make sure that the cooling system works correctly. To do this, lightly loosen the bottle cap and use the lever to open the valve. Then, turn the handles to the left to apply a light pressure on the pilot pin. The coolant should fill the system and start flowing from the cutter.

The cooling system works by gravity. Thus, in the inverted or horizontal position, use coolants under pressure or in the form of spray or paste.

3.7. Drilling

Set the speed based on the table that follows.

Tool	Hole diameter		Rotational speed* [rpm]	Gear switch setting
	[mm]	[in]		
HSS annular cutter	12–20	0.47–0.79	390–580	
	21–50	0.83–1.97	160–250	
TCT annular cutter	12–25	0.47–0.98	390–580	
	26–50	1.02–1.97	160–250	
Twist drill bit	14–23	0.55–0.91	160–250	

* For a sharp tool and mild steel with a strength $R_m < 500 \text{ N/mm}^2$ (70,000 psi), such as St0 (S185), St3S (S235JR), or St4W (S275JO).

Turn the gear switch as shown in the figure until you feel resistance. Incorrect setting can damage the gearbox.

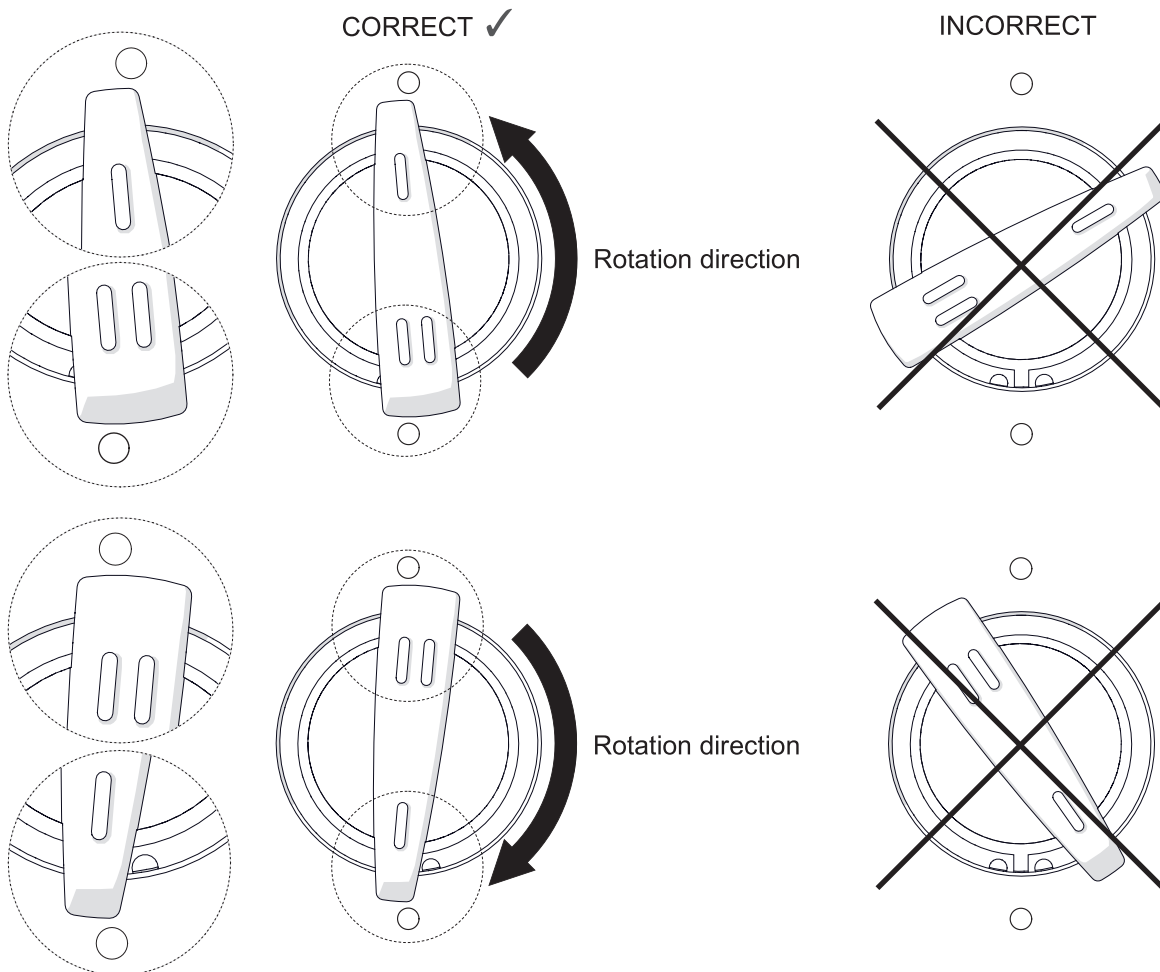

Steel with a strength $R_m \geq 500 \text{ N/mm}^2$ (70,000 psi), such as St5 (E295), 18G2A (S355N), or 45 (C45), requires lower speeds. If the speed is too high or too low for the workpiece strength and the type/diameter of the tool, the tool will wear faster or be unable to drill the hole.

Press  to start the motor. Turn the handles to the left to put the tool into the workpiece. Use the speed knob to set a speed sufficient for the actual process conditions. Set the speed knob near the maximum.



When the annular cutter goes through the workpiece, the slug core is pushed out with a large force.

When you use an annular cutter, drill only through holes. For incomplete through holes do not use the pilot pin.

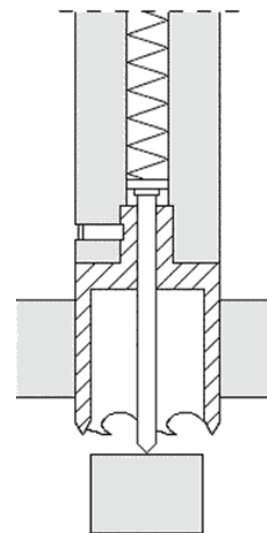
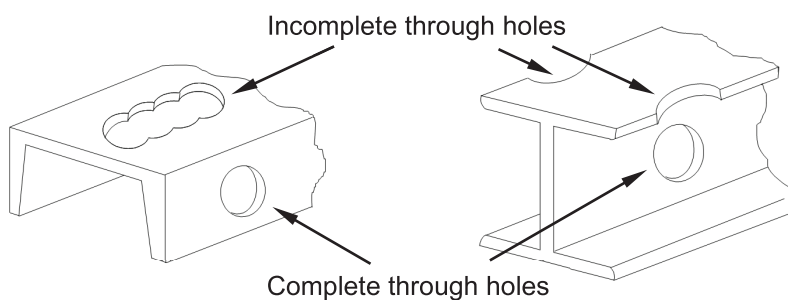



Keep the machine in the same position until the hole is made.

When you use a drill bit, drill holes with diameters of 18–23 mm (0.71–0.91") in two steps. First, use the drill bit with the 70% diameter of the required diameter to drill a hole. Then, keep the machine in the same position, and drill again with the drill bit that matches the required diameter.

If you are going to drill holes deeper than 50 mm (2"), retract the tool above the workpiece as often as possible. This allows chips to be removed from the hole. If the grooves of the tool are clogged, turn off the motor and use a brush to clean them.

After you get to the depth of 40 mm (1.6"), retract the tool above the workpiece as often as possible. Then, manually apply the coolant from the bottle into the drilling area.

The table that follows shows the meaning of the LED colors.

Color	Meaning	Description
Green is on	Strong surface.	Ready to work.
Green flashes	Weak surface.	We do not recommend work.
White is on	Normal work.	–
Blue flashes	Near overload.	Do not increase the feed speed. This can cause emergency stop.
 Red is on	 Overheat.	 Immediately retract the tool from the workpiece! Operate with no load for 2–4 minutes to let the temperature of the motor decrease.
Blue is on	Emergency stop. Overload.	Make sure that the tool is sharp. Make sure that the motor speed and the feed are correct. Use coolant. Retract the tool from the workpiece, press STOP, and then start again.
Violet is on	Emergency stop. Machine tilt/vibrations or the surface not stable.	Make sure that the surface is stable and its thickness is at least 10 mm (0.4"). Press STOP and then start again. If the motor does not operate, contact the service center.
Red changes to blue	Emergency stop. Voltage drop.	Make sure that the power source is correct. Press STOP and then start again.
Red changes to green	Emergency stop. Worn brushes.	Replace the brushes. Let the motor operate with no load for 20 minutes. If the motor does not operate, contact the service center.



The green color is indicative only. It does not make sure that the machine will always be in contact with the surface. Thus, in each position protect the machine with the safety strap.

If an overload occurs, the machine stops. The overload can be caused by not enough cooling, dull tool, too fast feed, or too slow speed. Then, to start the machine again, retract the tool from the workpiece, press STOP and then .

After the hole is made, retract the tool from the workpiece, and press STOP to turn off the motor. Before you move the machine, set the MAGNET switch to 'O' to turn off the base.

After the work is finished and the motor turned off, set the gear switch to the opposite position. Then, turn on the motor and let it operate for a while with no load to improve lubrication. Next, turn off the motor and the base, and then unplug the power cord. Clean the machine and the tool, and then remove the machine from the work area.

Tighten the bottle cap, close the valve, and then press the pilot pin to remove the coolant that remains in the cooling system. Before you put the machine into the box, remove the bottle, and use gloves to remove the tool from the holder.



3.8. Thread cutting

Install the screw tap and use the gear switch to set the speed to 160–250 rpm.

Rotational speed [rpm]	Gear switch setting
160–250	

Turn the handles to the left to put the tap above the hole for the thread. If the diameter of the hole is too small, cutting may not be possible because of too much milling resistance.

Apply oil on the cutting part of the tap to prevent seizure and increase durability.

Press  to start the motor. Set the speed knob near the minimum. Then, turn the handles to the left to put the tap into the hole. Use the handle to guide the tap down until the thread is cut. After the cutting with the tap is finished, press STOP to turn off the motor. Then, press and hold  and use the handle to guide the tap up to prevent damage to the thread.

After the work is finished and the motor turned off, set the gear switch to the opposite position. Start the motor and let it operate for a while with no load to improve lubrication. Next, turn off the motor and the base, and then unplug the power cord.

3.9. Adjusting the gibs

Every 50 work hours, make sure that the gibs are correctly adjusted. To do this, move the motor up and down and make sure that it moves smoothly.

To adjust the gibs, apply a thin layer of grease on them. Then, use the 8 mm combination wrench, the 2.5 mm hex wrench, and the 4 mm hex wrench to loosen the nuts and screws (1). Put the motor so that the slider is in the center of the gibs (2). Then, lightly tighten the screws (3) so that they touch the gib. Move the motor up and down and adjust the screws (3) so that the travel is smooth. Next, tighten the screws (4) and then tighten the nuts (5).

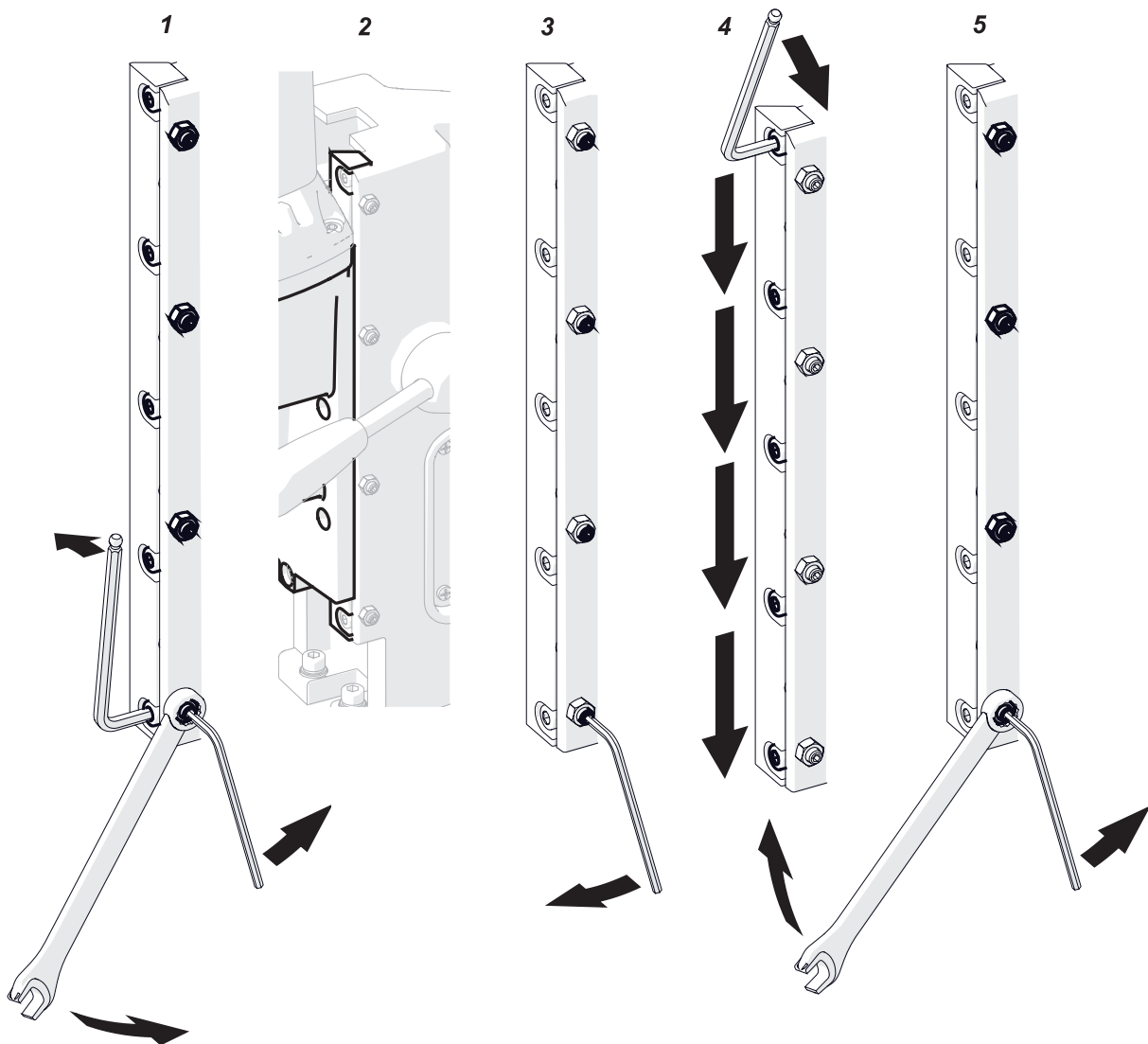

4. WIRING DIAGRAMS

4.1. Electronic control unit ass

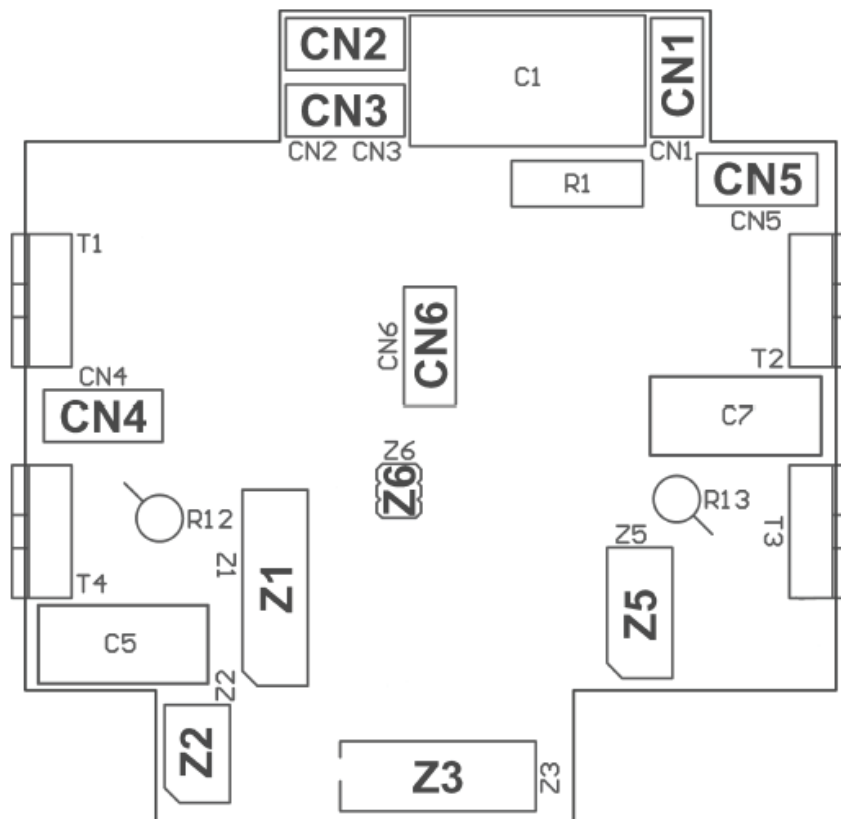

4.2. Wiring diagram

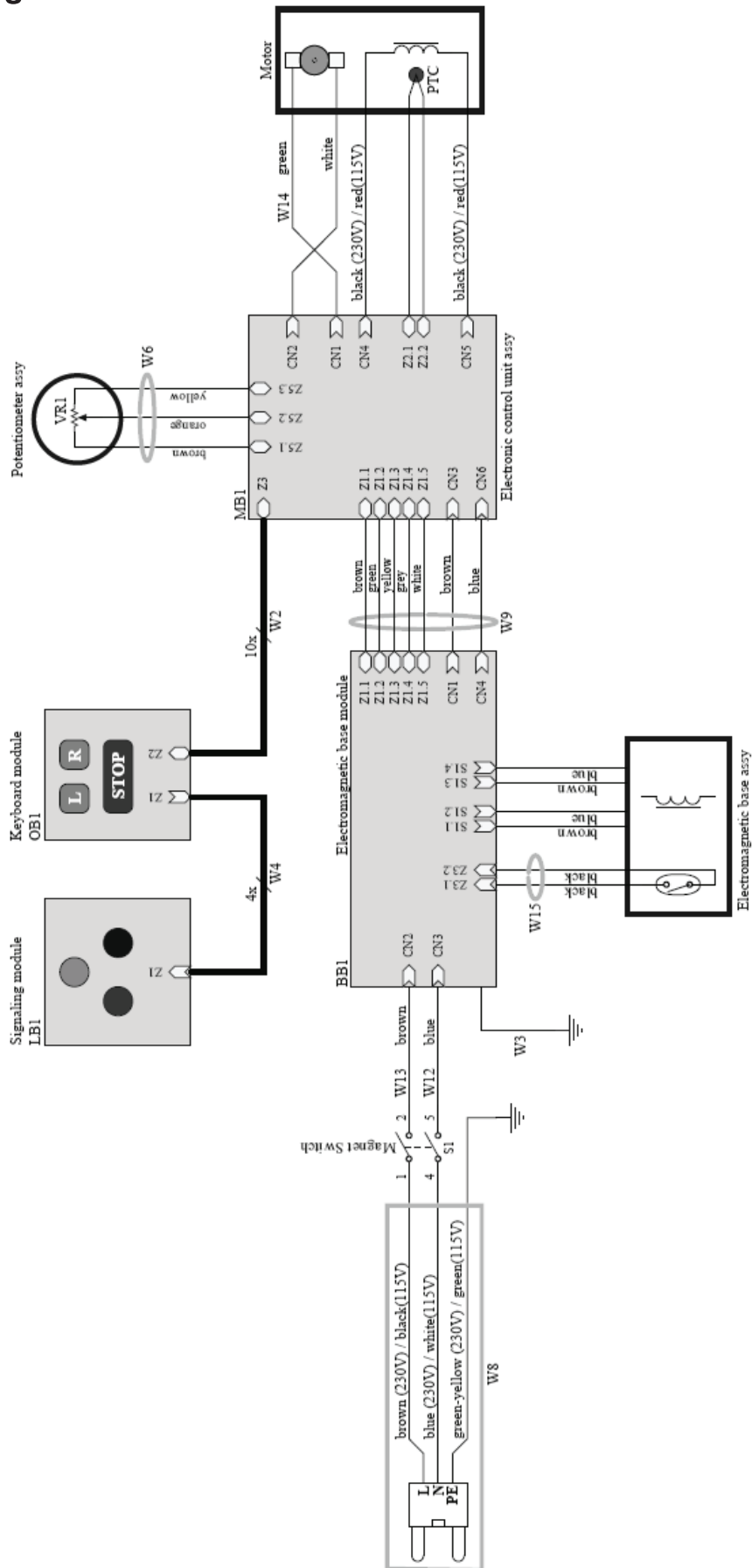

5. PARTS LIST

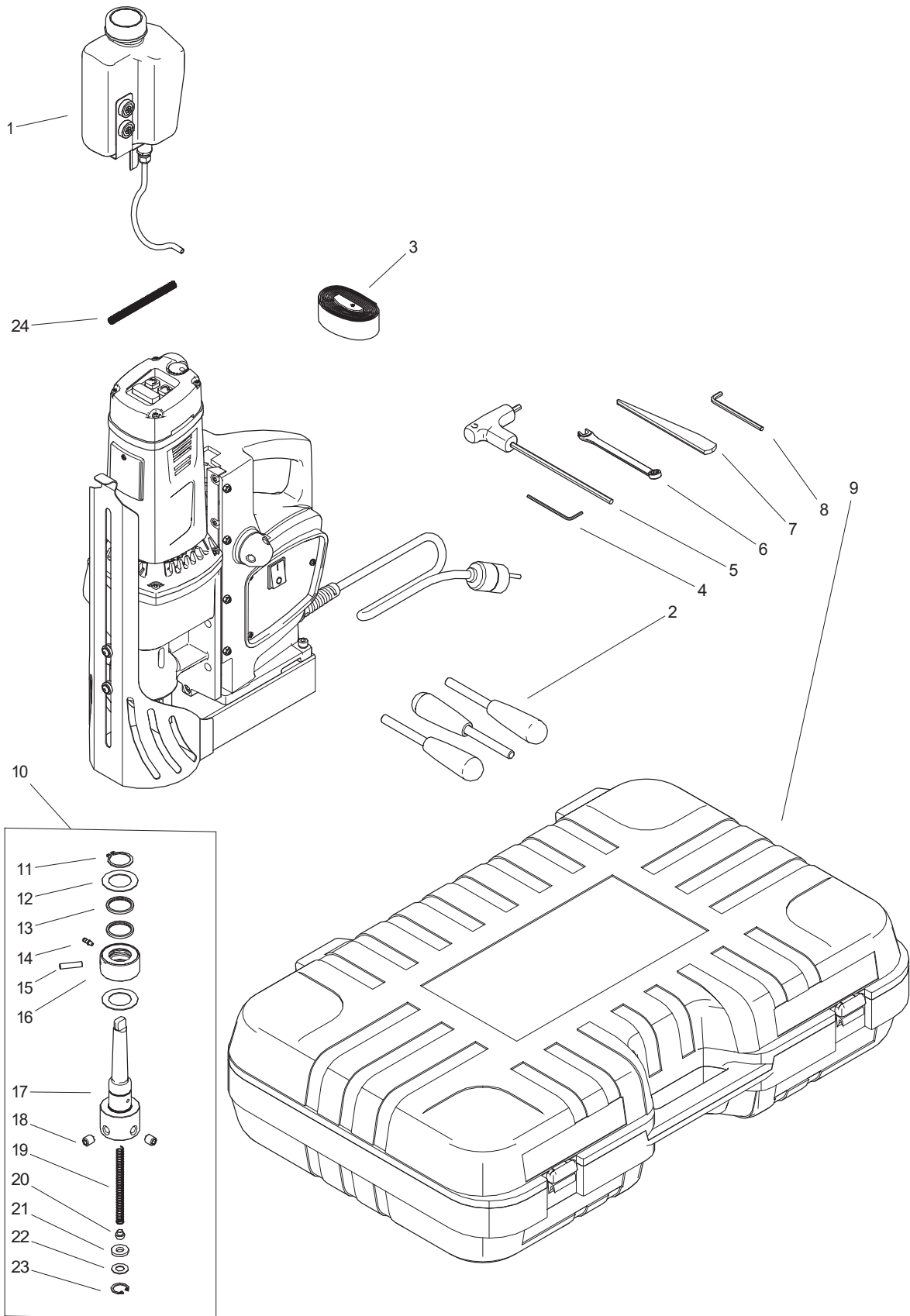

ITEM	PART NUMBER	DESCRIPTION	QTY
1	UKL-0600-11-00-00-0	COOLANT SYSTEM ASSY	1

ITEM	PART NUMBER	DESCRIPTION	QTY
2	DZW-0212-12-00-00-0	SPOKE HANDLE ASSY	3
3	PAS-000008	5 MM HEX WRENCH	1
4	KLC-000005	2.5 MM HEX WRENCH	1
5	KLC-000037	5 MM HEX WRENCH WITH HANDLE	1
6	KLC-000003	8 MM COMBINATION WRENCH	1
7	KLN-0103-01-00-00-0	WEDGE MT2	1
8	KLC-0600-10-00-00-0	4 MM HEX WRENCH	1
9	SKR-000017	BOX	1
10	UCW-0220-00-00-01-0	ARBOR ASSY AMT2-C-19/2-2	1
11	PRS-000017	EXTERNAL RETAINING RING 25z	1
12	PDK-0234-00-09-00-0	WASHER II	2
13	PRS-000105	SEAL O-RING 25.2x3	2
14	KNC-0257-05-03-04-1	CONNECTOR	1
15	PRT-0151-06-13-00-7	ROD L=35	1
16	TLJ-0284-00-07-00-3	COOLING SLEEVE	1
17	KRP-0220-00-02-00-0	ARBOR BODY AMT2-C-19/2-2	1
18	WKR-000032	HEX SOCKET SET SCREW WITH FLAT POINT	2
19	SPR-000002	SPRING	1
20	WYP-0203-06-02-00-0	PLUNGER	1
21	USZ-0203-06-03-00-0	SEAL	1
22	PDK-0139-00-04-00-0	WASHER 18.8x10x1	1
23	PRS-000009	INTERNAL RETAINING RING 19w	1
24	OSL-0399-17-00-00-0	SAFETY SPRING	1

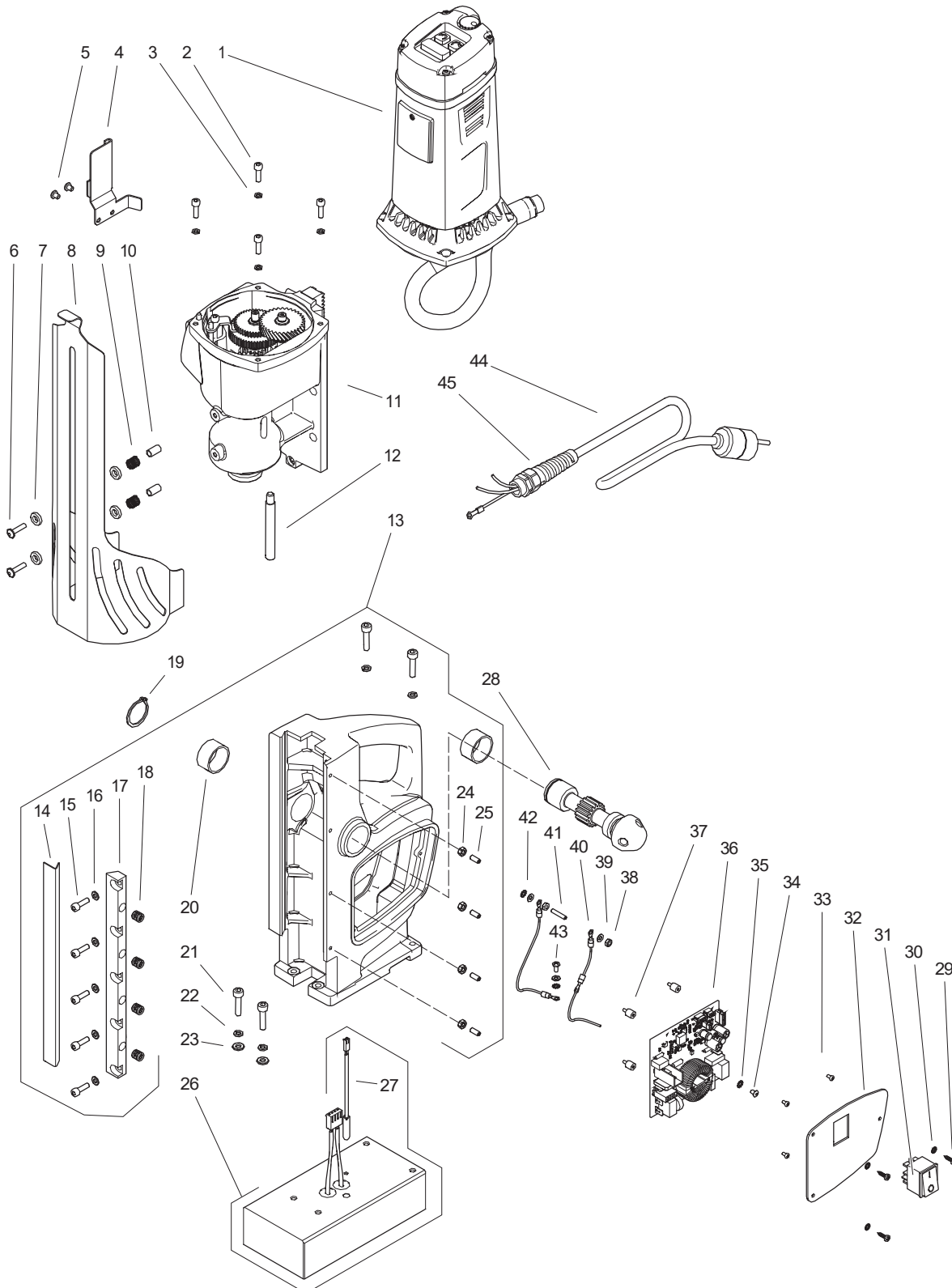

ITEM	PART NUMBER	DESCRIPTION	QTY
1	SLN-0600-01-00-00-0	MOTOR – 115V	1
1	SLN-0600-01-00-00-1	MOTOR – 230V	1
2	SRB-000083	HEX SOCKET HEAD CAP SCREW M5x16	4
3	PDK-000044	SPRING WASHER 5.1	4
4	MCW-0600-04-00-00-0	COOLANT BOTTLE BRACKET	1
5	WKR-000413	CROSS RECESSED PAN HEAD SCREW M5x6	2

6	WKR-000395	HEX SOCKET ROUND HEAD SCREW WITH FLANGE M5x20	2
7	PDK-000151	NYLON WASHER 8.1x14x3	4
8	OSL-0600-05-00-00-0	GUARD	1
9	SPR-000030	PUSH SPRING 1x10x17.5	2
10	TLJ-0399-06-00-00-0	SLEEVE	2
11	ZSP-0600-02-00-00-0	GEARBOX ASSY	1
12	DYS-0399-05-00-00-0	STOP ROD	1
13	KRP-0600-03-01-00-0	BODY ASSY	1
14	LST-0600-03-01-03-0	GIB	1
15	SRB-000085	HEX SOCKET SCREW M5x16	5
16	PDK-000017	WASHER 5,3	5
17	LST-0600-03-01-02-0	ADJUSTABLE GIB	1
18	SPR-000043	SPRING 1.6x8x14.5	4
19	PRS-000019	EXTERNAL RETAINING RING 28z	1
20	TLJ-000010	SELF-LUBRICATING SLEEVE 28,05H7x32x16	2
21	SRB-000115	HEX SOCKET SCREW M6x25	4
22	PDK-000046	SPRING WASHER 6.1	4
23	PDK-000020	WASHER 6.4	2
24	NKR-000015	HEX NUT M5	4
25	WKR-000044	HEX SOCKET HEAD CUP SCREW M5x12	5
26	PDS-0600-03-02-00-0	ELECTROMAGNETIC BASE ASSY	1
27	WZK-0563-03-02-02-0	REED WIRES SET (W15)	1
28	WLK-0630-03-02-00-0	PINION SHAFT	1
29	WKR-000415	CROSS RECESSED PAN HEAD SELF-TAPPING SCREW 3.5x13	3
30	PDK-000161	EXTERNAL TOOTH LOCK WASHER 3.7	3
31	PNK-000013	MAGNET SWITCH	1
32	MSK-0600-06-01-00-0	PANEL PLATE	1
33	WKR-000180	CROSS RECESSED PAN HEAD SCREW M3x5	3
34	PDK-000166	EXTERNAL TOOTH LOCK WASHER 4,3	1
35	WKR-000192	HEX SOCKET HEAD CUP SCREW M4x6	1
36	MDL-0600-80-03-00-0	ELECTROMAGNETIC BASE MODULE (BB1) – 115V	1
36	MDL-0600-80-04-00-0	ELECTROMAGNETIC BASE MODULE (BB1) – 230V	1
37	WBR-000004	DAMPER	3
38	NKR-000013	HEX NUT M4	2
39	PDK-000016	WASHER 4.3	3
40	PWD-0563-03-10-00-0	SAFETY WIRE SET (W3)	1
41	WKR-000519	HEX SOCKET HEAD CUP SCREW M4x20	1
42	PDK-000060	EXTERNAL TOOTH LOCK WASHER 4.3	2
43	WKR-000193	CROSS RECESSED PAN HEAD SCREW M4x8	1
44	PWD-0600-08-01-00-0	POWERCORD 115V WITH STRAIN RELIEF ASSY (AWG) (W8)	1
44	PWD-0600-08-02-00-0	POWERCORD 230V WITH STRAIN RELIEF ASSY (EU) (W8)	1
44	PWD-0600-08-03-00-0	POWERCORD 230V WITH STRAIN RELIEF ASSY (AUSTRALIA) (W8)	1
44	PWD-0600-08-04-00-0	POWERCORD 230V WITH STRAIN RELIEF ASSY (INDIE) (W8)	1
44	PWD-0600-08-05-00-0	POWERCORD 230V WITH STRAIN RELIEF ASSY (UK) (W8)	1
45	DLW-000007	CABLE GLAND WITH STRAIN RELIEF PG13.5	1
46*	PWD-0563-10-00-00-0	GROUNDING WIRE SET	1

*not shown in the drawing

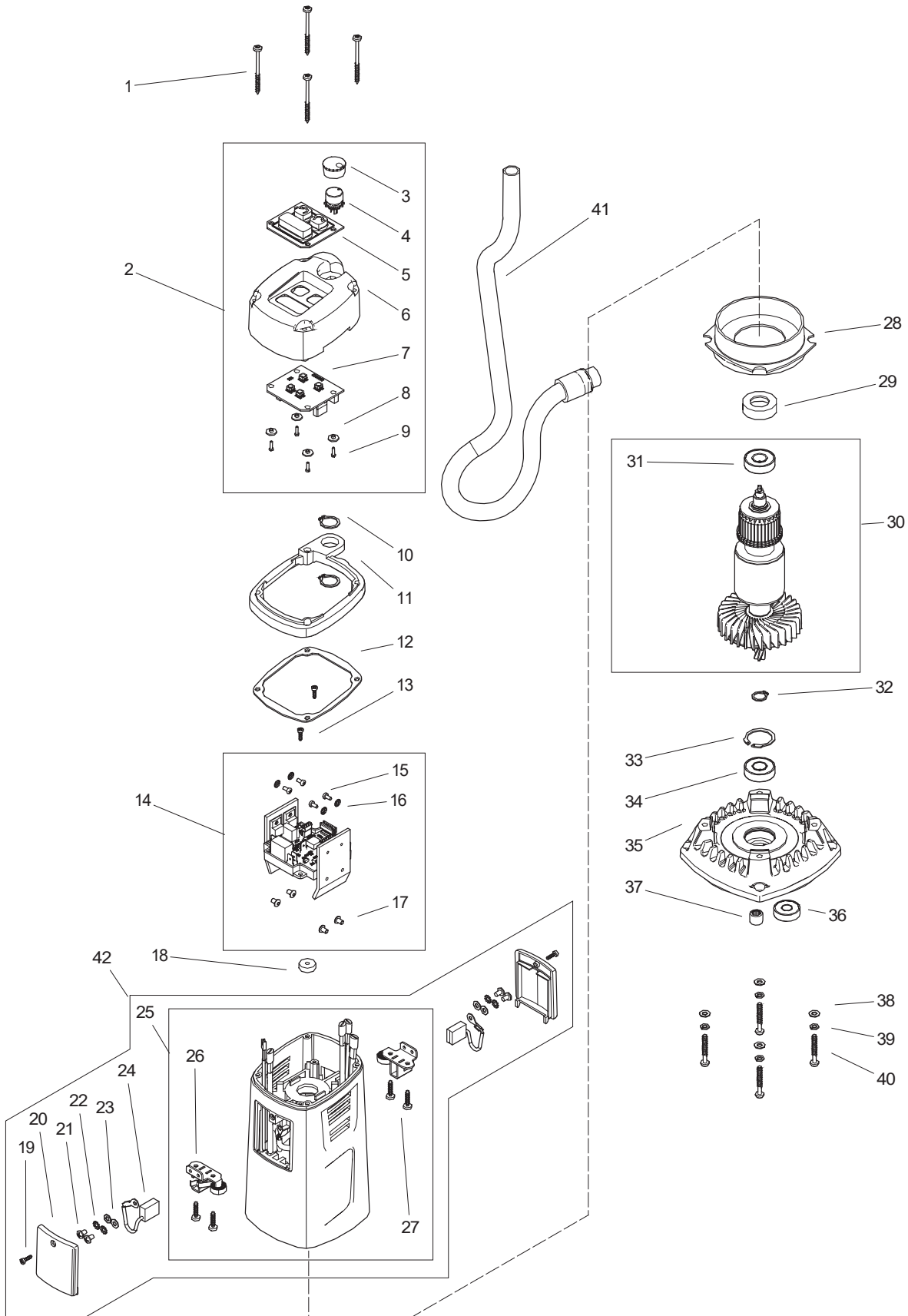

ITEM	PART NUMBER	DESCRIPTION	QTY
1	WKR-000529	TORX PAN HEAD SCREW 4x50	4
2	PKR-0563-01-06-00-0	STATOR COVER ASSY	1

ITEM	PART NUMBER	DESCRIPTION	QTY
3	PKT-0563-01-06-04-0	POTENTIOMETER KNOB	1
4	PTN-000039	POTENTIOMETER	1
5	OSL-0563-01-06-02-0	BUTTON COVER	1
6	PKR-0563-01-06-01-0	STATOR COVER	1
7	MDL-0563-80-05-01-0	KEYBOARD MODULE (OB1)	1
8	TLJ-000151	INSULATION SLEEVE 2.6x3.9	4
9	WKR-000458	SCREW FOR PLASTIC 2.2x8	4
10	PRS-000238	EXTERNAL RETAINING RING 16z	2
11	SYG-0563-01-05-01-0	SIGNALLER	1
12	MDL-0563-80-04-00-0	SIGNALING MODULE (LB1)	1
13	WKR-000506	SCREW FOR PLASTIC 3x10	2
14	ZSP-0600-07-00-00-0	ELECTRONIC CONTROL UNIT ASSY (MB1) - 115V	1
14	ZSP-0600-07-00-00-1	ELECTRONIC CONTROL UNIT ASSY (MB1) - 230V	1
15	WKR-000181	CROSS RECESSED PAN HEAD SCREW M3x6	4
16	PDK-000058	EXTERNAL TOOTH LOCK WASHER 3,2	4
17	WKR-000292	HEX SOCKET HEAD CUP SCREW M4x6	4
18	IMP-000002	PULSE GENERATOR	1
19	WKR-000506	SCREW FOR PLASTIC 3x10	2
20	PKR-0563-01-09-00-0	BRUSH COVER	2
21	WKR-000192	CROSS RECESSED PAN HEAD SCREW M4x6	4
22	PDK-000060	EXTERNAL TOOTH LOCK WASHER 4.3	4
23	PDK-000015	ROUND WASHER 4.3	4
24	SCZ-000035	BRUSH – 115V	2
24	SCZ-000036	BRUSH – 230V	2
25	OBD-0600-99-01-00-0	STATOR HOUSING ASSY – 115V	2
25	OBD-0600-99-01-00-1	STATOR HOUSING ASSY – 230V	2
26	SCT-000013	BRUSH HOLDER	2
27	WKR-000300	SCREW FOR PLASTIC 4x16	4
28	OBD-0563-01-07-00-0	FAN COVER	1
29	WKL-000046	BEARING INSERT	1
30	WRN-0600-99-00-00-0	ROTOR ASSY – 115V	1
30	WRN-0600-99-00-00-1	ROTOR ASSY – 230V	1
31	LOZ-000158	BALL BEARING 12x28x8	1
32	PRS-000003	EXTERNAL RETAINING RING 12z	1
33	PRS-000356	INTERNAL RETAINING RING 28w	1
34	LOZ-000025	BALL BEARING 12x28x8	1
35	PKR-0630-01-02-01-1	GEARBOX COVER	1
36	LOZ-000057	BALL BEARING 9x24x7	1
37	LOZ-000006	NEEDLE BEARING 8x12x10	1
38	PDK-000017	ROUND WASHER 5.3	4
39	PDK-000044	SPRING WASHER 5.1	4
40	WKR-000525	TORX PAN HEAD TAPPING SCREW 5x30	4
41	WZK-0600-01-03-00-0	MOTOR WIRE SET (W9)	1
42	OBD-0600-99-02-00-0	MOTOR COVER WITH STATOR ASSY – 115V	1
42	OBD-0600-99-02-00-1	MOTOR COVER WITH STATOR ASSY – 230V	1
43*	WZK-0563-01-06-07-0	POTENTIOMETER WIRE SET (W6)	1
44*	WZK-0563-01-11-00-0	LED WIRE SET (W4)	1
45*	WZK-0563-01-12-00-0	CONTROLLER WIRE SET (W2)	1
46*	PWD-0563-01-13-00-0	BRUSH HOLDER WIRE (W14)	1
47*	PWD-0563-09-02-00-0	CONTROLLER WIRE SET (W12)	1
48*	PWD-0563-09-03-00-0	CONTROLLER WIRE SET (W13)	1

*not shown in the drawing

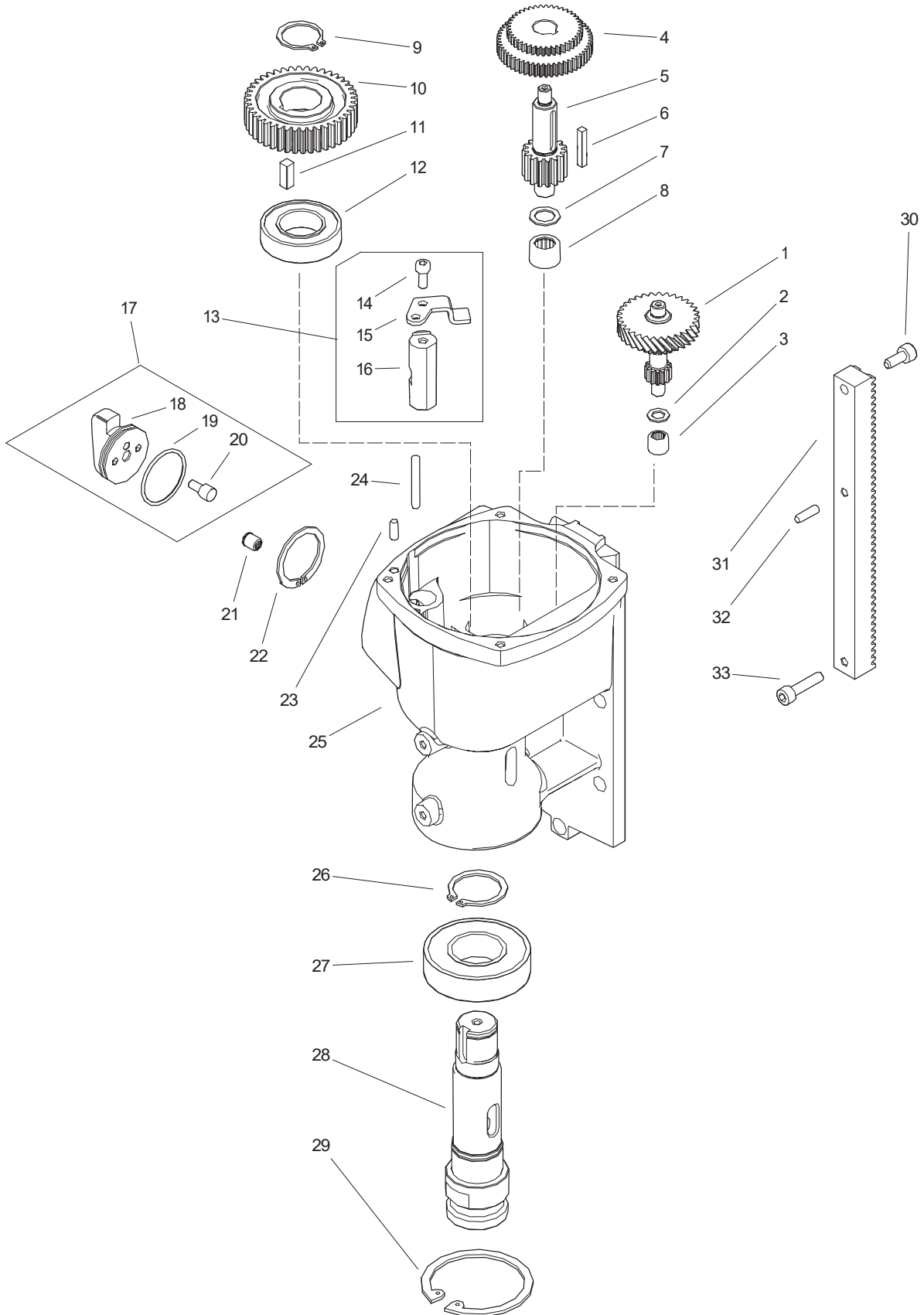

ITEM	PART NUMBER	DESCRIPTION	QTY
1	WLK-0630-02-02-00-0	CLUTCH SHAFT ASSY	1
2	PDK-0211-00-16-00-0	WASHER 8,1x13x1	1
3	LOZ-000006	NEEDLE BEARING 8x12x10	1

ITEM	PART NUMBER	DESCRIPTION	QTY
4	KOL-0630-02-03-00-0	GEAR z42 z54 m=1	1
5	WLK-0600-02-04-00-0	GEAR SHAFT z15 m=1,5	1
6	WPS-0563-02-20-00-1	PARALLEL KEY 4x4x25	1
7	PDK-000164	WASHER 12x18x1	1
8	LOZ-000171	NEEDLE BEARING 12x18x12	1
9	PRS-000322	EXTERNAL RETAINING RING 24z	1
10	KOL-0600-02-03-00-0	GEAR z42 m=1,5	1
11	WPS-0630-02-08-00-0	PARALLEL KEY 6x6x16	1
12	LOZ-000028	BALL BEARING 25x47x12	1
13	WDZ-0630-02-07-00-0	SLIPPER ASSY	1
14	SRB-000078	HEX SOCKET HEAD CUP SCREW M5x12	1
15	ZCZ-0630-02-07-02-0	SLIPPER BRACKET	1
16	WLK-0630-02-07-01-0	SLIPPER SHAFT	1
17	PKT-0563-02-12-00-0	SHIFT KNOB ASSY	1
18	KRP-0563-02-12-01-1	SHIFT KNOB	1
19	PRS-000327	OS-RING - 32x2	1
20	KLK-0599-02-09-02-0	KNOB PIN	1
21	ZTR-000001	BALL LOCK 8	1
22	PRS-000346	INTERNAL RETAINING RING 36w	1
23	KLK-000045	DOWEL PIN 5n6x12	1
24	KLK-000111	DOWEL PIN 5n6x35	1
25	KRP-0600-02-01-01-1	GEARBOX BODY	1
26	PRS-000021	EXTERNAL RETAINING RING 30z	1
27	LOZ-000075	BALL BEARING 30x62x16	1
28	WRZ-0600-02-02-00-0	SPINDLE	1
29	PRS-000035	INTERNAL RETAINING RING 62w	1
30	SRB-000105	HEX SOCKET HEAD CAP SCREW M6x14	1
31	LST-0600-02-01-02-0	GEAR RACK	1
32	KLK-000047	DOWEL PIN 5n6x16	1
33	SRB-000117	HEX SOCKET HEAD CAP SCREW M6x25	1
34*	SMR-000001	GRASE	0,3

*not shown in the drawing